

SKID-STEER DRUM MULCHER

72"(1829MM) DRUM MULCHER HEAD

SERIAL #25446+

WARRANTY + SERVICE 888.960.0364

PARTS 888.960.0361



DIAMONDMOWERS.COM

TABLE OF CONTENTS

DRUM MULCHER HEAD

DECK ASSEMBLY.....	4
DRIVE ASSEMBLY.....	5
DECK FEED ASSEMBLY.....	6
DRUM ASSEMBLY.....	7
DECAL ASSEMBLY.....	8

APPENDIX

S.A.E. TORQUE SPECIFICATIONS.....	10
METRIC TORQUE SPECIFICATIONS.....	11

DRUM MULCHER HEAD

DRUM MULCHER HEAD

DECK ASSEMBLY

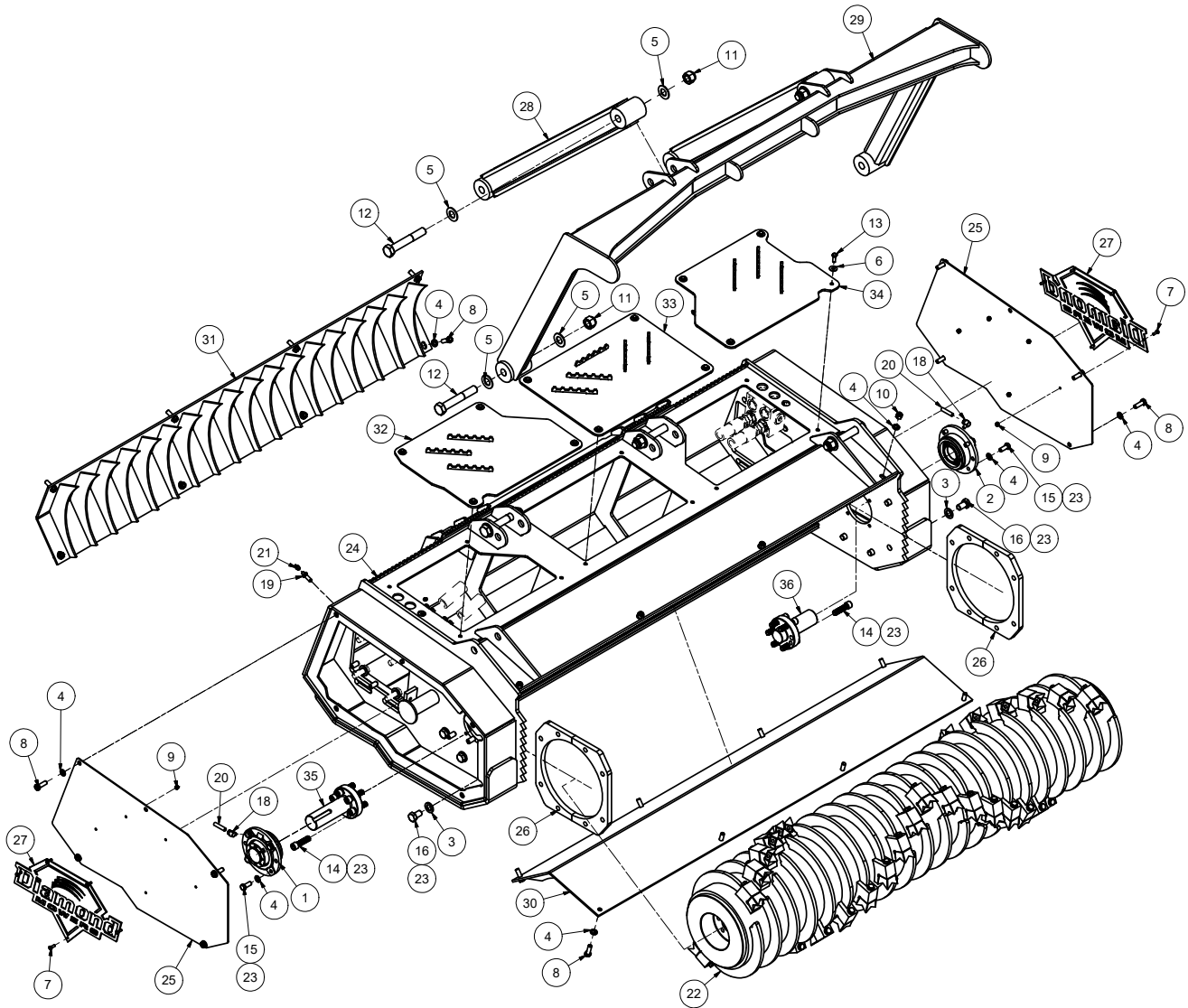

REF#	PARTS DESCRIPTION	REQ	PART#	TORQUE (ft-lbs)	TORQUE (Nm)
1	BEARING, DRIVE SIDE, DRUM MULCHER	1	10-0104		
2	BEARING, NON DRIVE, DRUM MULCHER	1	10-0105		
3	3/4 SAE GR 8 FLAT WASHER, YELLOW	16	11-0039		
4	1/2 X 1.062 GR 8 SAE FLAT WASHER, YELLOW ZINC	36	11-0042		
5	1 SAE FLAT WASHER GR 8	12	11-0056		
6	3/8 THRU-HARDENED FLAT WASHER, YELLOW ZINC	12	11-0092		
7	1/4-20 X 3/4 GR 5 HEX CAP, ZINC	10	11-0588	8.4	11.4
8	1/2-13 X 1-1/2 GR 8 HEX CAP SCREW, YELLOW ZINC	24	11-0972	106	144
9	1/4-20 GR 2 NYLOCK NUT, ZINC	10	11-1022		
10	1/2-13 GR 8 NYLOCK NUT, ZINC	12	11-1072	106	144
11	1 NC NYLOCK NUT, GR 8	6	11-1082		
12	1-8 X 6-1/2 GR 8 HEX CAP, YELLOW ZINC	6	11-1622	909	1232
13	3/8-16 X 1 GR 8 HEX CAP, YELLOW ZINC	12	11-1624	44	60
14	5/8-11 X 2-1/2 SHCS, ASTM A574, BLACK OXIDE	12	11-1657	238	323
15	1/2-13 X 1-1/4 GR 8 HEX CAP, YELLOW ZINC	8	11-2203	106	144
16	3/4-10 X 1-1/4 GR 8 HEX CAP, YELLOW ZINC	16	11-2204	376	510
*17	DECAL KIT, FORESTRY DRUM MULCHER	1	15-5128		
18	ELBOW 1/8" X 90	2	21-1104		

REF#	PARTS DESCRIPTION	REQ	PART#	TORQUE (ft-lbs)	TORQUE (Nm)
19	BULKHEAD, 1/8 MP X 1/4 MJIC	2	21-1687		
20	GREASE HOSE, 1/8" X 24" (1/8MP X 1/4 FJIC)	2	21-4635		
21	GREASE ZERK 1/8" FEM. NPT	2	23-0008		
22	72 DRUM ASSEMBLY, GEN II PATTERN	1	24-0308		
23	LOCTITE 262, .017 OZ (RED)	1	24-0382		
24	72" DRUM MULCHER	1	25-0221		
25	BELT COVER, DRUM MULCHER	2	31-0644		
26	ANTI-WRAP BLOCK, DRUM MULCHER	4	31-0659		
27	DIAMOND LOGO CUTOUT	2	31-0670		
28	PUSH BAR BRACE TUBE, DRUM MULCHER	2	41-1600		
29	PUSH BAR, DRUM MULCHER	1	41-1601		
30	UPPER LINER, DRUM MULCHER	1	41-1602		
31	LOWER LINER, SKID DRUM MULCHER	1	41-1603		
32	RIGHT TOP GRIPPER COVER, FDS072	1	41-1771		
33	CENTER GRIPPER COVER, FDS072	1	41-1772		
34	LEFT GRIPPER COVER, FDS072	1	41-1773		
35	DRIVE SHAFT, DRUM MULCHER	1	90-7058		
36	IDLER SHAFT, DRUM MULCHER	1	90-7059		

* NOT SHOWN

25-1736-1 Rev E

DRUM MULCHER HEAD

DRIVE ASSEMBLY

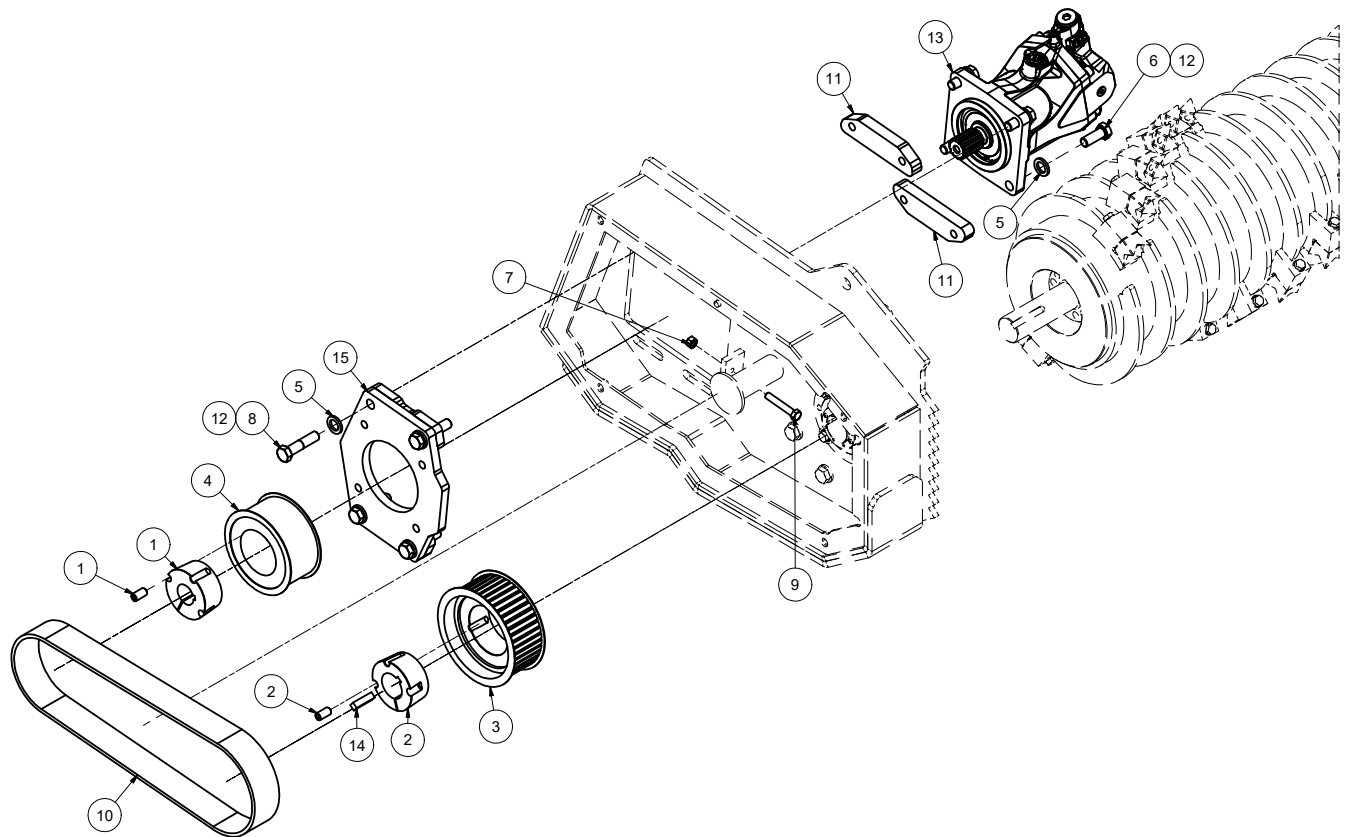

REF#	PARTS DESCRIPTION	REQ	PART#	TORQUE (ft-lbs)	TORQUE (Nm)
1	BUSHING, 1-3/4 13T, DRUM MULCHER	1	10-1060	60	81
2	BUSHING, 2-3/16 KEYED, DRUM MULCHER	1	10-1061	60	81
3	PULLEY, 201MM X 85MM, DRUM MULCHER	1	10-1063		
4	PULLEY, 165MM X 85MM, DRUM MULCHER	1	10-1064		
5	3/4 SAE GR 8 FLAT WASHER, YELLOW	8	11-0039		
6	3/4-10 X 2 GR 8 HEX CAP, YELLOW ZINC	4	11-0751	376	510
7	1/2-13 GR 5 HEX NUT, ZINC	1	11-1016		
8	3/4-10 X 3-1/4 GR 8 HEX CAP, YELLOW ZINC	4	11-2205	376	510
9	1/2-13 X 3 GR 8 HEX CAP, YELLOW ZINC FULL THREAD	1	11-2206	106	144
10	BELT, HT500, 68MM X 1568MM, DRUM MULCHER	1	12-0082		
11	MOTOR MOUNT CLAMP PLATE, DRUM MULCHER	2	24-0368		
12	LOCTITE 262, .017 OZ (RED)	1	24-0382		
13	MVA115, VARIABLE DISPLACEMENT BENT AXIS PISTON MOTOR	1	30-0575		
	CONTROLLER, MVA115, 3000 PSI CARRIER SETTING		39-1128		
	CONTROLLER, MVA115, 3300 PSI CARRIER SETTING		39-1129		
	CONTROLLER, MVA115, 3500 PSI CARRIER SETTING		39-1130		
	CONTROLLER, MVA115, 4000 PSI CARRIER SETTING		39-1131		
14	KEY 1/2 X 1/2 X 2	1	37-0026		
15	MOTOR MOUNT, DRUM MULCHER	1	41-1606		

DRUM MULCHER HEAD

DECK FEED ASSEMBLY

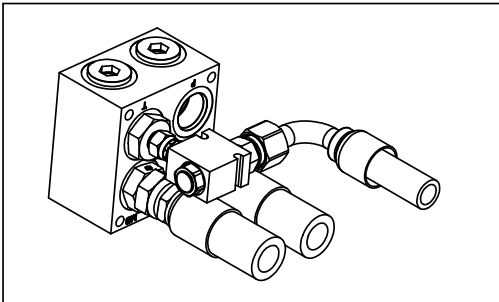
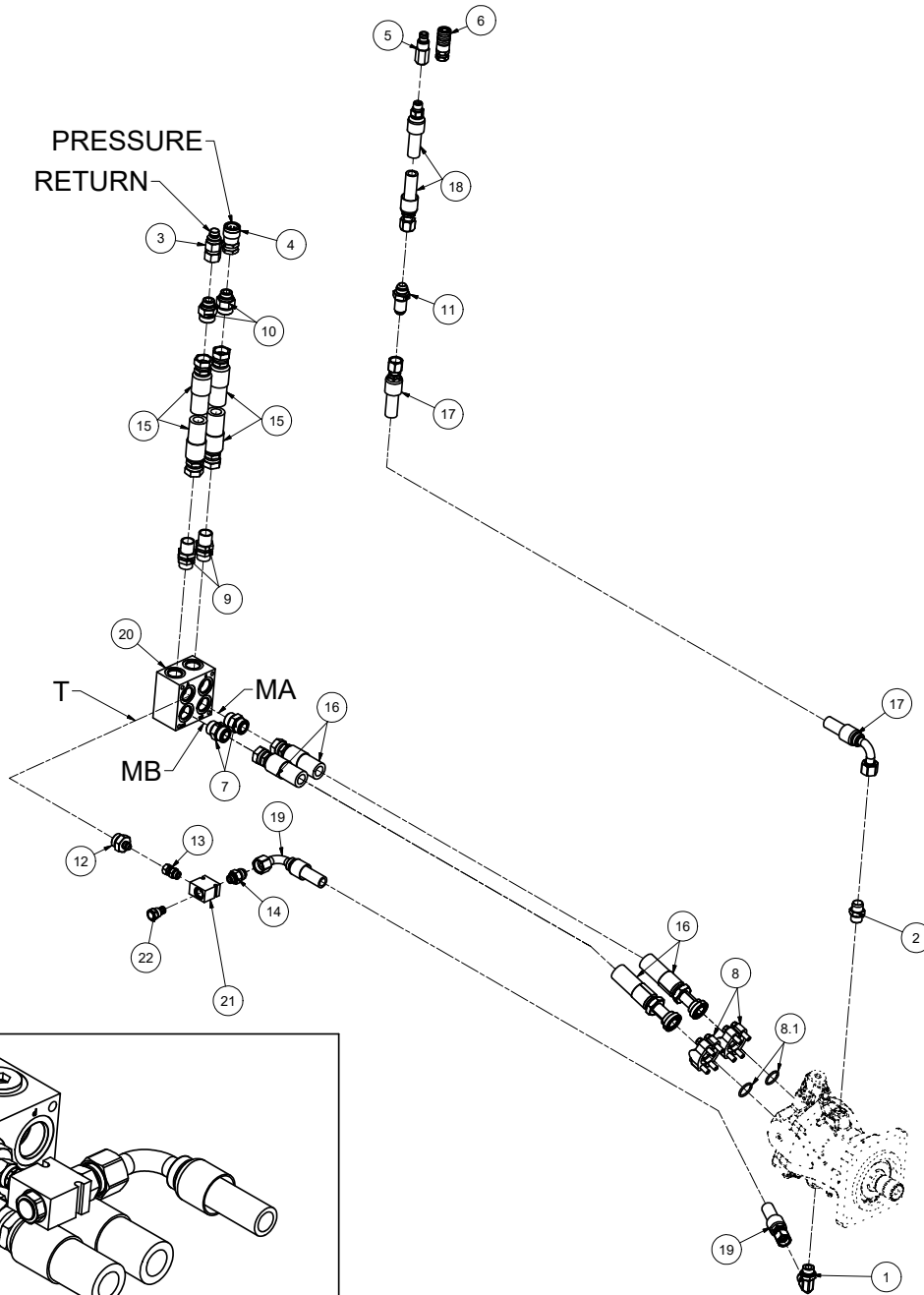

REF#	PARTS DESCRIPTION	REQ	PART#	TORQUE (ft-lbs)	TORQUE (Nm)
1	3/4ADJ MOR X 3/4MJIC 90 DEG ADAPTER	1	21-1276		
2	3/4MORB X 3/4MJIC, ADAPTOR	1	21-1475		
3	1/2" MALE QUICK COUPLER X 3/4" SAE, FLAT FACE, NO SPILL	1	21-1559		
4	1/2" FEMALE QUICK COUPLER X 3/4" SAE, FLAT FACE, NO SPILL	1	21-1560		
5	3/8" MALE QUICK COUPLER, FLAT FACE, NO SPILL	1	21-1561		
6	3/8" FEMALE QUICK COUPLER, FLAT FACE, NO SPILL	1	21-1562		
7	-16 MOR X -16 MOFS	2	21-1675		
8	1 FLANGE KIT, CODE 62	2	21-1677	49	66
8.1	-62 FLANGE ORING	2	33-0105		
9	BULKHEAD, -16 MOFS X -16 MORB	2	21-1686		
10	ADAPTER, -16 MFS X -12 MOR	2	21-1692		
11	BULKHEAD, -12MJIC X -12MJIC	1	21-1709		
12	ADAPTER, 1 MORB X 1/2 MJIC	1	21-1727		

REF#	PARTS DESCRIPTION	REQ	PART#
13	ADAPTER, 1/2MORB X 1/2FJIC	1	21-1728
14	ADAPTER, 1/2MORB X 3/4MJIC	1	21-1729
15	HOSE, 1 X 91, 4000 PSI (-16 FFS X -16 FFS)	2	21-4617
16	HOSE, 1 X 61, 4000 PSI (-16 CODE 62 FLANGE X -16 FFS)	2	21-4632
17	HOSE, 3/4 X 78 (-12FJIC 90 DEG X -12 FJIC)	1	21-4738
18	HOSE, 3/4 X 96 (-12FJIC X -8MP)	1	21-4739
19	HOSE, 3/4 X 78 (-12FJIC 90 DEG X -12 FJIC)	1	21-4803
20	MANIFOLD, ANTI-CAVITATION, ATTACHMENT	1	39-0121
21	CHECK BODY, 2 WAY, 1/2 ORB PORTS	1	39-1153
22	CHECK, CARTRIDGE STYLE, 5000 PSI, 16 GPM	1	39-1154
OPTIONAL QUICK COUPLERS			
	5/8 MALE QUICK COUPLER, FLAT FACE		21-1574
	5/8 FEMALE QUICK COUPLER, FLAT FACE		21-1575
	3/4 MALE QUICK COUPLER, FLAT FACE		21-1576
	3/4 FEMALE QUICK COUPLER, FLAT FACE		21-1577

25-1736-3 Rev F

* NOT SHOWN

DRUM MULCHER HEAD

DRUM ASSEMBLY

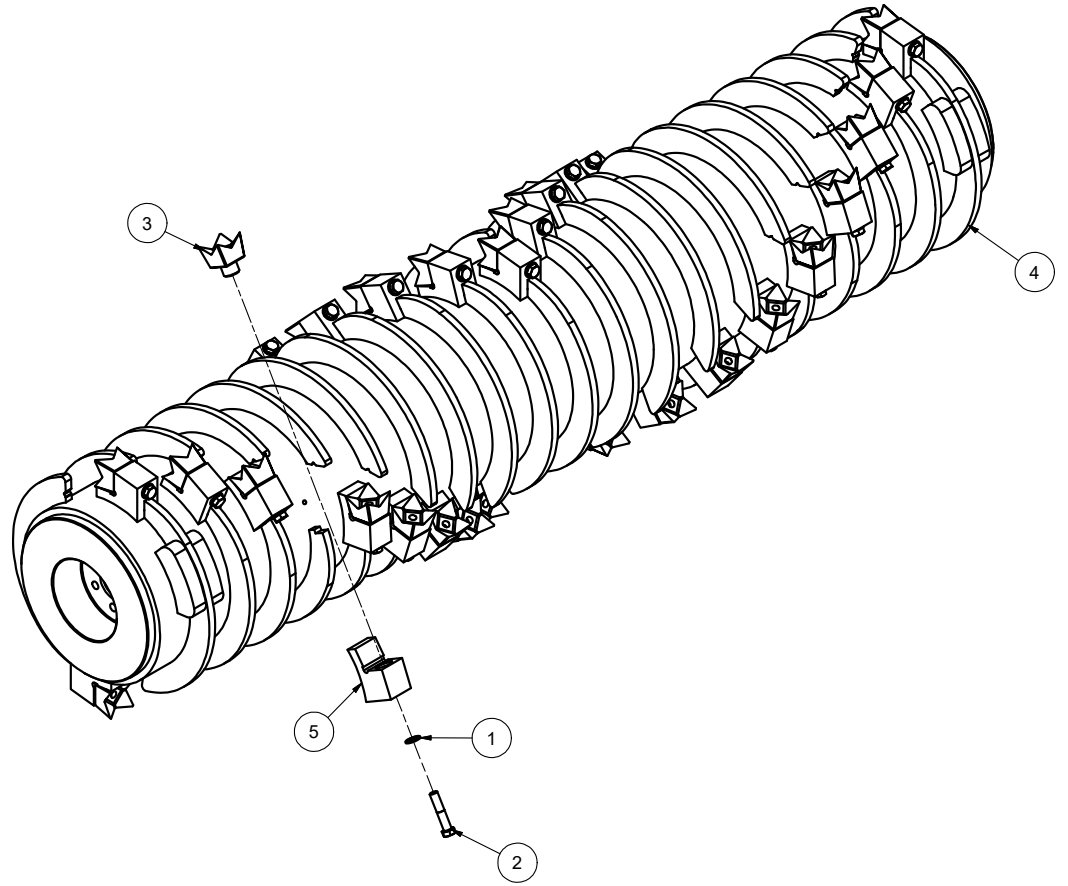

REF#	PARTS DESCRIPTION	REQ	PART#	TORQUE ft-lbs	TORQUE Nm
1	1/2 X 1.062 GR 8 SAE FLAT WASHER, YELLOW ZINC	41	11-0042		
2	1/2-20 X 2-1/2 GR 8 HEX CAP, YELLOW ZINC	41	11-1079	120	163
3	TOOTH	41	22-0019		
4	DRUM WELDMENT, SKID, GEN II PATTERN	1	41-1702		
5	TOOTH HOLDER, DRUM MULCHER	41	90-7062		

24-0308

Rev 000

DRUM MULCHER HEAD

DECAL ASSEMBLY

- ① PART #15-0057 - Decal Group (horizontal) - QTY 2
- ② PART #15-1018 - Warranty and Service - QTY 1
- ③ PART #15-0055 - Made in the USA - QTY 1
- ④ PART #15-0058 - Read Manual - QTY 1
- ⑤ PART #15-0076 - Stay Back 300ft / 100m (72") - QTY 1
- ⑥ PART #15-0068 - Patent Denis Cimaf - QTY 1
- ⑦ SERIAL NUMBER LABEL - (not included in kit) - QTY 1
- ⑧ PART #15-0005 - Grease Here - QTY 2
- ⑨ PART #15-0077 - Variable Displacement Motor Notice - QTY 1
- ⑩ PART #15-0105 - Safety Polycarbonate Tag - QTY 1
- ⑪ CARRIER PSI LABEL - (not included in kit) - QTY 1
- ⑫ PART #15-0102 - Shift Control Module ID (machine interior) - QTY 1
- ⑬ PART #15-0114 - Belt Tension Notice (machine interior) - QTY 1
- ⑭ PART #15-0115 - Stay Back 300ft / 100m (60") - QTY 1

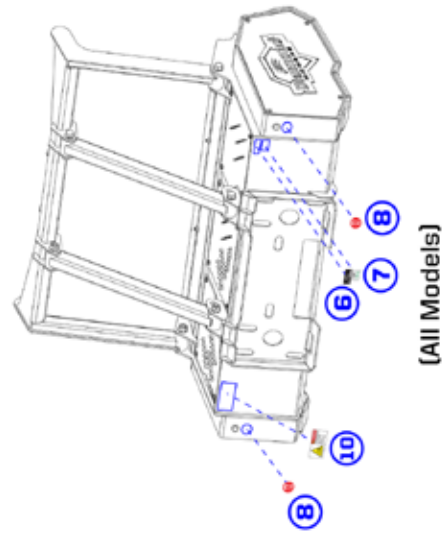
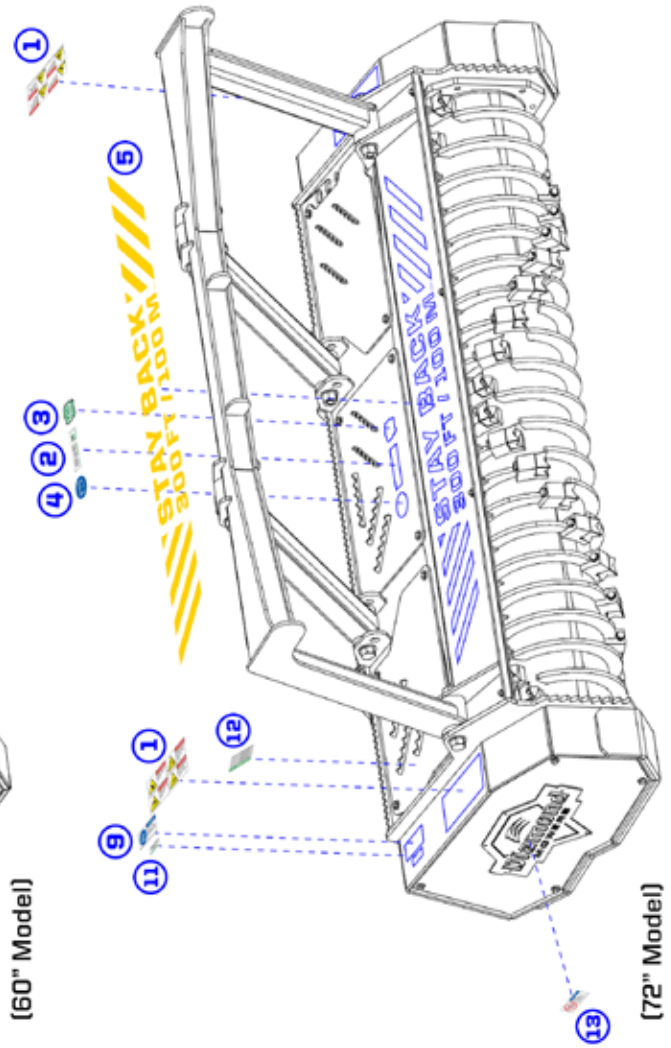
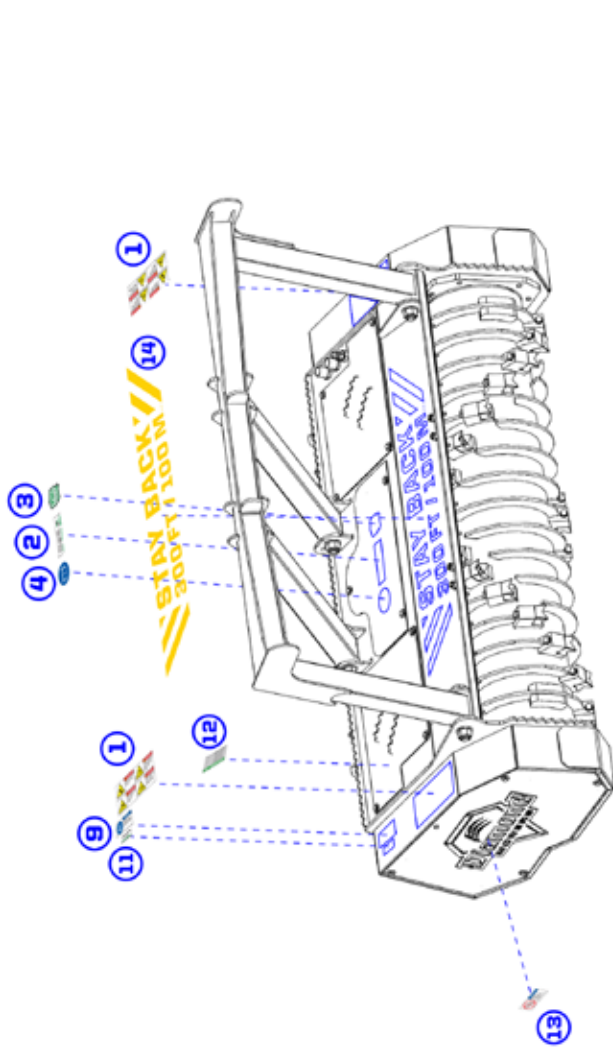

06/2019

APPENDIX

S.A.E. TORQUE SPECIFICATIONS



Torque-Tension Relationship for A307A, Grade 5, 8 & 9 Bolts

Nominal Dia. (in.)	threads per inch	Tensile Stress Area (sq. in.)	ASTM A307 Grade A					SAE J429 Grade 5					SAE J429 Grade 8					FNL Grade 9				
			Clamp Load (Lbs.)	Tightening Torque			Clamp Load (Lbs.)	Tightening Torque			Clamp Load (Lbs.)	Tightening Torque			Clamp Load (Lbs.)	Tightening Torque						
				K = 0.15	K = 0.17	K = 0.20		K = 0.15	K = 0.17	K = 0.20		K = 0.15	K = 0.17	K = 0.20		K = 0.15	K = 0.17	K = 0.20				
Unified Coarse Thread Series																						
1/4	20	0.0318	859	32 in-lbs	37 in-lbs	43 in-lbs	2029	76 in-lbs	86 in-lbs	101 in-lbs	2864	107 in-lbs	122 in-lbs	143 in-lbs	3357	126 in-lbs	143 in-lbs	168 in-lbs				
5/16	18	0.0524	1416	66	75	88	3342	157	178	209	4719	221	251	295	5531	259	294	346				
3/8	16	0.0775	2092	10 ft-lbs	11 ft-lbs	13 ft-lbs	4940	23 ft-lbs	26 ft-lbs	31 ft-lbs	6974	33 ft-lbs	37 ft-lbs	44 ft-lbs	8174	38 ft-lbs	43 ft-lbs	51 ft-lbs				
7/16	14	0.1063	2870	16	18	21	6777	37	42	49	9568	52	59	70	11214	61	70	82				
1/2	13	0.1419	3831	24	27	32	9046	57	64	75	12771	80	90	106	14969	94	106	125				
9/16	12	0.1819	4912	35	39	46	11599	82	92	109	16375	115	130	154	19193	135	153	180				
5/8	11	0.2260	6102	48	54	64	14408	113	128	150	20340	159	180	212	23840	186	211	248				
3/4	10	0.3345	9030	85	96	113	21322	200	227	267	30101	282	320	376	35281	331	375	441				
7/8	9	0.4617	12467	136	155	182	29436	322	365	429	41556	455	515	606	48707	533	604	710				
1	8	0.6057	16355	204	232	273	38616	483	547	644	54517	681	772	909	63899	799	905	1065				
1 1/4	7	0.9691	26166	409	463	545	53786	840	952	1121	87220	1363	1545	1817	102229	1597	1810	2130				
1 1/2	6	1.4053	37942	711	806	949	77991	1462	1657	1950	126473	2371	2688	3162	148237	2779	3150	3706				
Fine Thread Series																						
1/4	28	0.0364	982	37 in-lbs	42 in-lbs	49 in-lbs	2319	87 in-lbs	99 in-lbs	116 in-lbs	3274	123 in-lbs	139 in-lbs	164 in-lbs	3837	144 in-lbs	163 in-lbs	192 in-lbs				
5/16	24	0.0581	1568	73	83	98	3702	174	197	231	5226	245	278	327	6125	287	325	383				
3/8	24	0.0878	2371	11 ft-lbs	13 ft-lbs	15 ft-lbs	5599	26 ft-lbs	30 ft-lbs	35 ft-lbs	7905	37 ft-lbs	42 ft-lbs	49 ft-lbs	9265	43 ft-lbs	49 ft-lbs	58 ft-lbs				
7/16	20	0.1187	3205	18	20	23	7568	41	47	55	10684	58	66	78	12523	68	78	91				
1/2	20	0.1600	4319	27	31	36	10197	64	72	85	14396	90	102	120	16873	105	120	141				
9/16	18	0.2030	5480	39	44	51	12940	91	103	121	18268	128	146	171	21412	151	171	201				
5/8	18	0.2560	6911	54	61	72	16317	127	144	170	23036	180	204	240	27000	211	239	281				
3/4	16	0.3730	10070	94	107	126	23776	223	253	297	33566	315	357	420	39343	369	418	492				
7/8	14	0.5095	13756	150	171	201	32479	355	403	474	45853	502	568	669	53743	588	666	784				
1	14	0.6799	18357	229	260	306	43343	542	614	722	61190	765	867	1020	71720	896	1016	1195				
1 1/4	12	1.0729	28970	453	513	604	59548	930	1055	1241	96565	1509	1710	2012	113182	1768	2004	2358				
1 1/2	12	1.5810	42688	800	907	1067	87747	1645	1865	2194	142292	2668	3024	3557	166778	3127	3544	4169				

The torque values can only be achieved if nut (or tapped hole) has a proof load greater than or equal to the bolt's minimum ultimate tensile strength. Clamp load calculated as 75% of the proof load when specified by the standard. ASTM A307 utilized 75% of 36,000 PSI. Torque values for 1/4 and 5/16-in series are in inch-pounds. All other torque values are in foot-pounds.

Torque values calculated from formula $T = KDF$, where

K = 0.15 for "lubricated" conditions

K = 0.17 for zinc plated and dry conditions; we have also found various forms of customer applied thread lockers to have a similar K value.

K = 0.20 for plain and dry conditions

D = Nominal Diameter

F = Clamp Load

Note: When using Zinc Plated (lubricated with wax) Top Lock Nuts, the K value can vary between 0.12-0.16

Caution: All material included in this chart is advisory only, and its use by anyone is voluntary. In developing this information, Fastenal has made a determined effort to present its contents accurately. Extreme caution should be used when using a formula for torque/tension relationships. Torque is only an indirect indication of tension. Under/over tightening of fasteners can result in costly equipment failure or personal injury.

METRIC TORQUE SPECIFICATIONS



Torque-Tension Relationship for Metric Fasteners

Nominal Dia. (mm)	Pitch	4.6 Class 4.6				8.8 Class 8.8				10.9 Class 10.9				12.9 Class 12.9			
		Clamp Load (lbs)	Tightening Torque			Clamp Load (lbs)	Tightening Torque			Clamp Load (lbs)	Tightening Torque			Clamp Load (lbs)	Tightening Torque		
			Lubricated (ft-lbs)	Zinc Plated (ft-lbs)	Plain&Dry (ft-lbs)		Lubricated (ft-lbs)	Zinc Plated (ft-lbs)	Plain&Dry (ft-lbs)		Lubricated (ft-lbs)	Zinc Plated (ft-lbs)	Plain&Dry (ft-lbs)		Lubricated (ft-lbs)	As-Received (ft-lbs)	Plain&Dry (ft-lbs)
4	0.7	333	0.7	0.7	0.9	858	1.7	1.9	2.3	1228	2.4	2.7	3.2	1436	2.8	3.2	3.8
5	0.8	538	1.3	1.5	1.8	1387	3.4	3.9	4.5	1985	4.9	5.5	6.5	2319	5.7	6.5	7.6
6	1	763	2.3	2.6	3.0	1968	5.8	6.6	7.7	2816	8.3	9.4	11.1	3291	9.7	11.0	13.0
7	1	1095	3.8	4.3	5.0	2822	9.7	11.0	13.0	4039	13.9	15.8	18.5	4720	16.3	18.4	21.7
8	1.25	1389	5.5	6.2	7.3	3580	14.1	16.0	18.8	5123	20.2	22.9	26.9	5987	23.6	26.7	31.4
10	1.5	2200	10.8	12.3	14.4	5671	27.9	31.6	37.2	8115	39.9	45.2	53.2	9484	46.7	52.9	62.2
12	1.75	3197	18.9	21.4	25.2	8240	48.7	55.1	64.9	11792	69.6	78.9	92.8	13781	81.4	92.2	108.5
14	2	4379	30.2	34.2	40.2	11289	77.8	88.1	103.7	16154	111.3	126.1	148.4	18879	130.0	147.4	173.4
16	2	5943	47	53	62	15320	121	137	161	21924	173	196	230	25622	202	229	269
18	2.5	7301	65	73	86	18822	167	189	222	26934	239	270	318	31477	279	316	372
20	2.5	9286	91	104	122	23938	236	267	314	34256	337	382	449	40034	394	446	525
22	2.5	11509	125	141	166	29669	321	364	428	42457	460	521	613	49619	537	609	716
24	3	13372	158	179	211	34471	407	461	543	49329	582	660	777	57649	681	771	908
27	3	17428	232	262	309	44924	597	676	796	64288	854	968	1139	75132	998	1131	1331
30	3.5	21266	314	356	419	54819	809	917	1079	78448	1158	1312	1544	91680	1353	1534	1804
33	3.5	26310	427	484	570	67821	1101	1248	1468	97055	1576	1786	2101	113425	1842	2087	2455
36	4	30982	549	622	732	79866	1415	1603	1886	114291	2024	2294	2699	133569	2366	2681	3154

The torque values can only be achieved if nut (or tapped hole) has a proof load greater than or equal to the bolt's minimum ultimate tensile strength.

Clamp loads estimated as 75% of proof load for specified bolts.

Torque values listed in foot-pounds.

Torque values calculated from formula $T = KDF$ where; $K = 0.15$ for "lubricated" condition, $K = 0.17$ for zinc plated and dry condition (or as-received for the 12.9), $K = 0.20$ for plain and dry condition

Caution: All material included in this chart is advisory only, and its use by anyone is voluntary. In developing this information, Fastenal has made a determined effort to present its contents accurately. Extreme caution should be used when using a formula for torque/tension relationships. Torque is only an indirect indication of tension. Under/over tightening of fasteners can result in costly equipment failure or personal injury.



Rev 3-4-09

**DEMAND
BRILLIANCE**