



PARTS BOOK

FLEXWING MOWERS

• 10' CUT • DRAWBAR MOUNT •

DIAMOND MOWERS, LLC
350 E 60th St. North
Sioux Falls, SD 57104

FOR WARRANTY CALL DIAMOND MOWERS DIRECT:
888-960-0364

OUR TECHNICIANS WILL DIAGNOSE YOUR SITUATION
OVER THE PHONE TO GET YOU UP AND RUNNING QUICKLY.

Phone: 605-977-3300
Fax: 605-655-5870
www.diamondmowers.com

DEMAND BRILLIANCE.

© DIAMOND MOWERS, LLC



Foreword

This manual contains the parts breakdown and identification of the various components and structures that make up your mower implement.

The illustrations, drawings, and diagrams in this manual are based on the latest information available at the time of publication. Your machine may have product improvements and features not yet contained in this parts manual.

Diamond Mowers, LLC reserves the right to make changes at any time without notice or obligation.

Diamond Mowers, LLC™ and Wetblade™ are trademarks of Diamond Mowers, LLC.

This manual should be consulted prior and while assembling the unit, and anytime parts or assembly clarification is needed.

Copyright© 2016 Diamond Mowers, LLC

All rights reserved. While every precaution has been taken in the preparation of this manual, the publisher assumes no responsibility for errors or omissions. No part of this book covered by the copyrights hereon may be reproduced or copied in any form or by any means - graphic, electronic, or mechanical, including photocopying, taping, or information storage and retrieval systems - without written permission of the publisher.



Table of Contents

FRAME ASSEMBLIES	4
FRAME ASSEMBLIES - CENTER FRAME, 15'/10' GEAR BOX DRIVE.....	5
FRAME ASSEMBLIES - CENTER FRAME, 15'/10' HYDRAULIC DRIVE.....	7
FRAME ASSEMBLIES - RIGHT WING, 15'/10' GEAR BOX DRIVE.....	9
FRAME ASSEMBLIES - RIGHT WING, 15'/10' HYDRAULIC DRIVE.....	10
FRAME ASSEMBLIES - LEFT SKIRT/COUNTER WEIGHT, 10' FLEXWINGS.....	11
FRAME ASSEMBLIES - HITCH ASSEMBLY, 15'/10' FLEXWINGS.....	12
CUTTER ASSEMBLIES	13
CUTTER ASSEMBLIES - TRI-HEX, 15'/10' GEAR BOX DRIVE.....	14
CASTER ASSEMBLIES	15
CASTER ASSEMBLIES - CENTER ASSEMBLY, 15'/10' GEAR BOX/HYDRAULIC DRIVE.....	16
CASTER ASSEMBLIES - RIGHT ASSEMBLY, 15'/10' GEAR BOX/HYDRAULIC DRIVE.....	17
CASTER ASSEMBLIES - LEFT ASSEMBLY, 15'/10' GEAR BOX/HYDRAULIC DRIVE.....	18
CASTER ASSEMBLIES - HUB/WHEEL ASSEMBLY.....	19
HYDRAULIC ASSEMBLIES	20
HYDRAULIC SYSTEMS - HYDRAULIC ASSEMBLY, 10' HYDRAULIC FLEXWING.....	21
HYDRAULIC SYSTEMS - REPHASING HEIGHT CONTROL, 10' FLEXWING.....	24
HYDRAULIC SYSTEMS - WING LIFT CONTROL, 10' FLEXWING.....	25
ELECTRICAL ASSEMBLIES	26
ELECTRICAL ASSEMBLIES - 10' HYDRAULIC FLEXWING, SCHEMATIC.....	27
LIMIT SWITCH - DRAFT BEAM HEIGHT LIMITER.....	29
DECK ASSEMBLIES	30
29-0049 - DRIVE LINE ASSEMBLY.....	31
29-0051 - DRIVE LINE ASSEMBLY.....	32
19-0077 - GEAR BOX ASSEMBLY, SPLITTER.....	33
19-0078 - GEAR BOX ASSEMBLY.....	34
19-0081 - GEAR BOX ASSEMBLY.....	35
30-0518 - MOTOR ASSEMBLY.....	36
30-0017 - PUMP ASSEMBLY.....	37
17-0014 - FILTER ASSEMBLY.....	38
35-0088 - DIRECT DRIVE SPINDLE.....	39
LIFT ASSEMBLIES	40
14-0001 - 3X10 WELDED CYLINDER.....	41
14-0040 - 2.8X8 REPHASING CYLINDER, 1.125" ROD.....	42

FRAME ASSEMBLIES



FRAME ASSEMBLIES - CENTER FRAME, 15'/10' GEAR BOX DRIVE

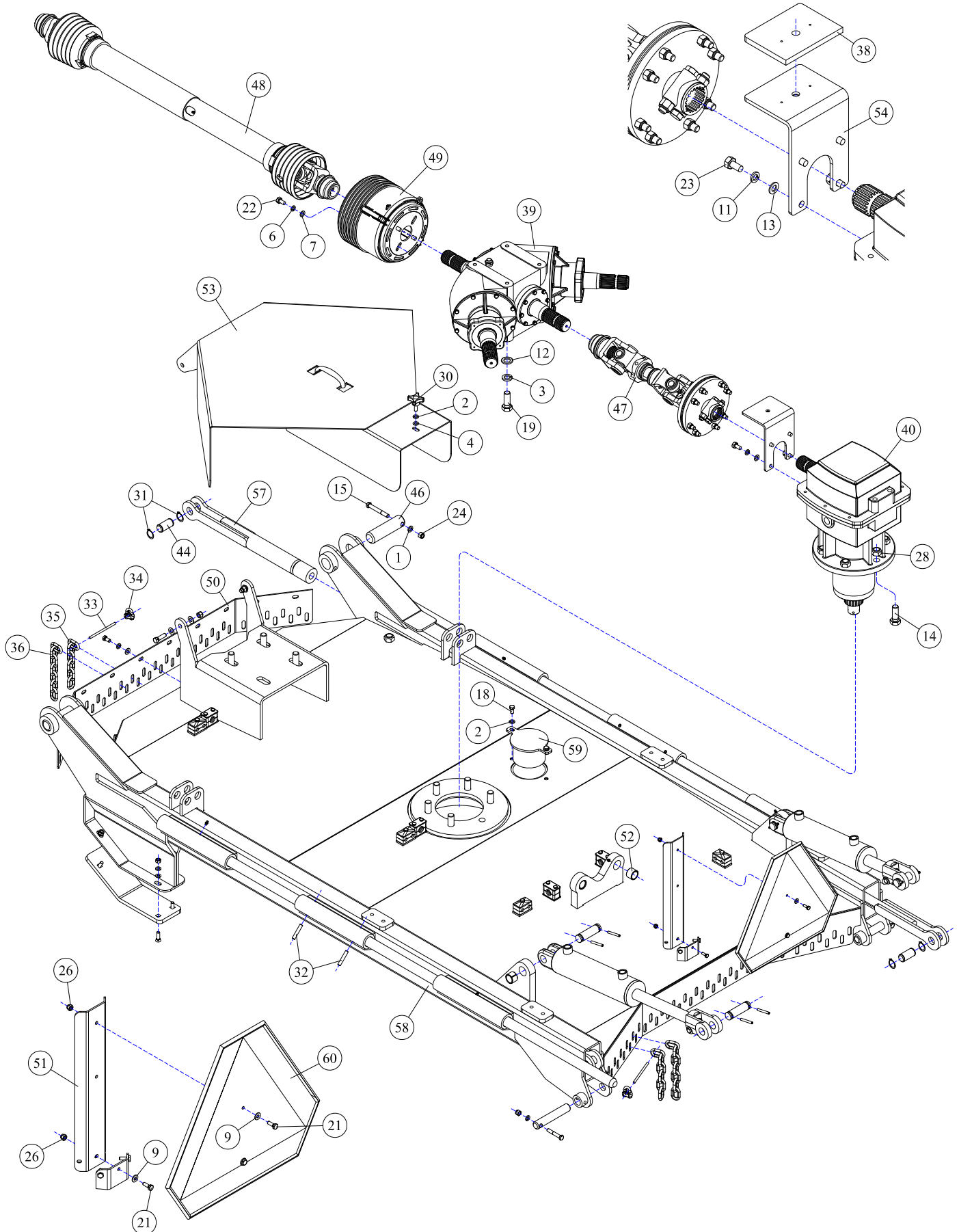

FRAME ASSEMBLIES - CENTER FRAME, 15'/10' GEAR BOX DRIVE

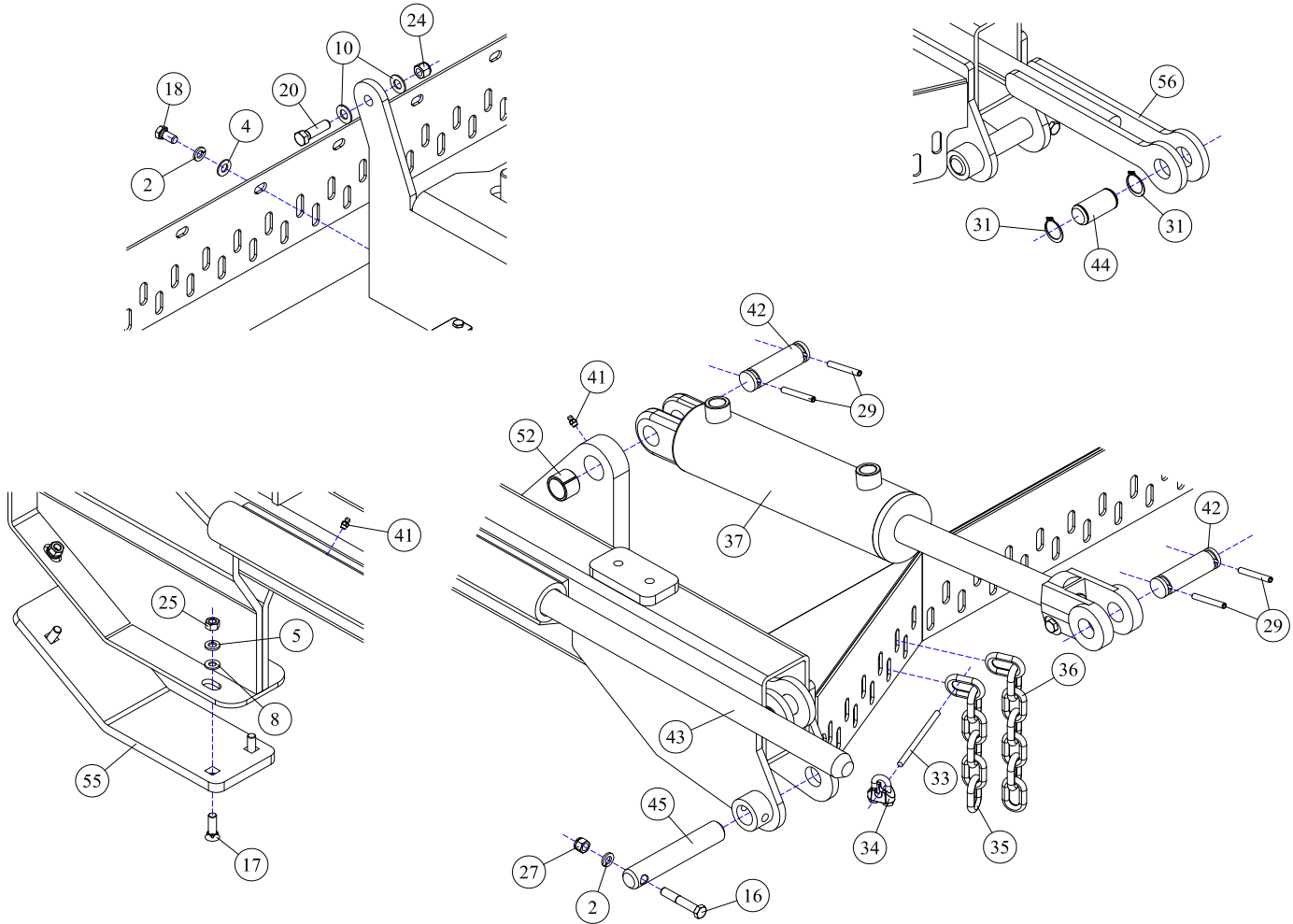

REF#	PARTS DESCRIPTION	REQ	PART #
1	7/16 LOCK WASHER	2	11-0003
2	3/8 LOCK WASHER	15	11-0005
3	3/4 LOCK WASHER	4	11-0007
4	3/8 FLAT WASHER	11	11-0009
5	1/2 LOCK WASHER	8	11-0011
6	5/16 LOCK WASHER	4	11-0013
7	5/16 FLAT WASHER	4	11-0015
8	1/2 FLAT WASHER	8	11-0018
9	1/4 FLAT WASHER	5	11-0023
10	7/16 FLAT WASHER	4	11-0024
11	10MM LOCK WASHER	4	11-0032
12	3/4 H.S. SAE FLAT WASHER	4	11-0039
13	10MM FLAT WASHER	4	11-0065
14	3/4 X 2-1/4 H.S. NF HEX CAPSCREW	6	11-0658
15	7/16 X 3-1/4 NC HEX CAPSCREW	2	11-0510
16	3/8 X 2-1/4 NC HEX CAPSCREW	2	11-0513
17	1/2 X 1-3/4 NC PLOW BOLT	8	11-0530
18	3/8 X 3/4 NC HEX CAPSCREW	12	11-0545
19	3/4 X 1-3/4 NC HEX CAPSCREW	4	11-0560
20	7/16 X 1-1/2 NC HEX CAPSCREW	2	11-0585
21	1/4 X 3/4 NC HEX CAPSCREW	5	11-0588
22	5/16 X 3/4 NC HEX CAPSCREW	4	11-0596
23	10MM X 20MM X 1.5 NC HEX CAPSCREW	4	11-0721
24	7/16 NC NYLOCK NUT	4	11-1003
25	1/2 NC HEX NUT	8	11-1016
26	1/4 NC NYLOCK NUT	5	11-1022
27	3/8 NC NYLOCK NUT	2	11-1024
28	3/4 H.S. NF STOVER NUT	6	11-1032
29	1/4 X 2 ROLLPIN	8	11-2005
30	3/8 X 1 NC 4-LOBE KNOB-SCREW	1	11-2029

REF#	PARTS DESCRIPTION	REQ	PART #
31	1" EXTERNAL SNAP-RING	8	11-2048
32	3/8 X 2 ROLLPIN	4	11-2050
33	1/4 GALVANIZED CABLE	Avail/ft	12-0032
34	CABLE CLAMP	4	12-0033
35	5/16" X 6 LINK, GR 30	51	12-0035
36	5/16" X 7 LINK, GR 30	51	12-0036
37	3 X 8 CYLINDER	2	14-0041
38	SHIELD PAD	1	18-0061
39	SPLITTER GEARBOX	1	19-0077
40	CENTER GEARBOX, 1000 RPM	1	19-0080
41	GREASE ZERK	10	23-0004
42	CLEVIS PIN	4	27-0004
43	HINGE PIN	2	27-0023
44	LIFT PIN	4	27-0026
45	BASE PIN	2	27-0029
46	HITCH PIN	2	27-0030
47	CENTER DRIVELINE	1	29-0050
48	DRIVE LINE, 1000 RPM	1	29-0051
49	INPUT CONNECTION SHIELD	1	29-0052
50	CHAIN BRACKET	1	31-0171
51	SMV BRACKET	1	31-0173
52	BUSHING	4	34-0005
53	CENTER SHIELD	1	41-0731
54	SHIELD BRACKET	1	41-0732
55	SKID SHOE	2	42-0029
56	LIFT ROD	2	49-6026
57	LIFT ROD END	2	49-6027
58	CENTER FRAME	1	49-6041
59	A ACCESS PORT COVER	1	80-3507
60	SMV SIGN	1	90-8018

FRAME ASSEMBLIES - CENTER FRAME, 15'/10' HYDRAULIC DRIVE

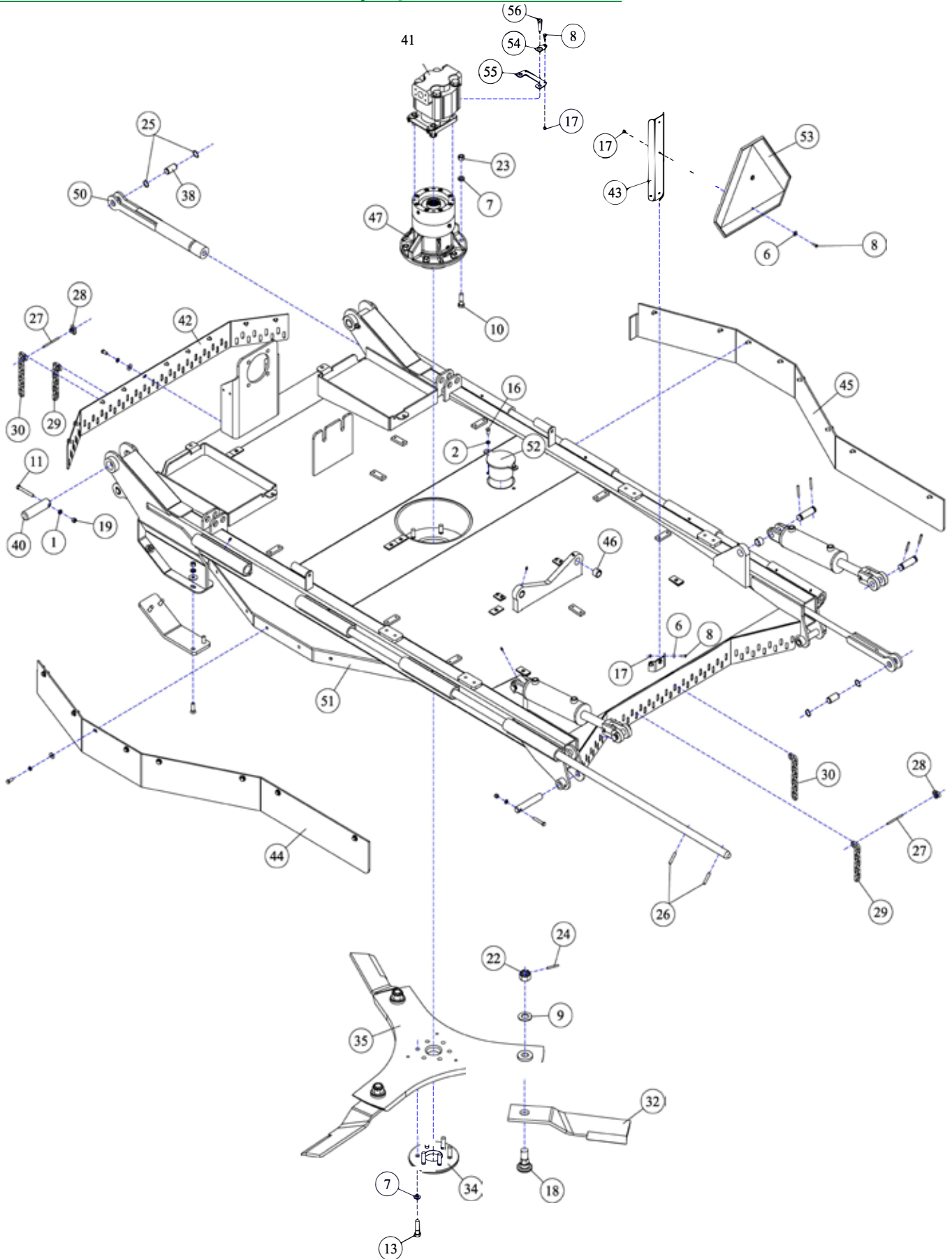

FRAME ASSEMBLIES - CENTER FRAME, 15'/10' HYDRAULIC DRIVE

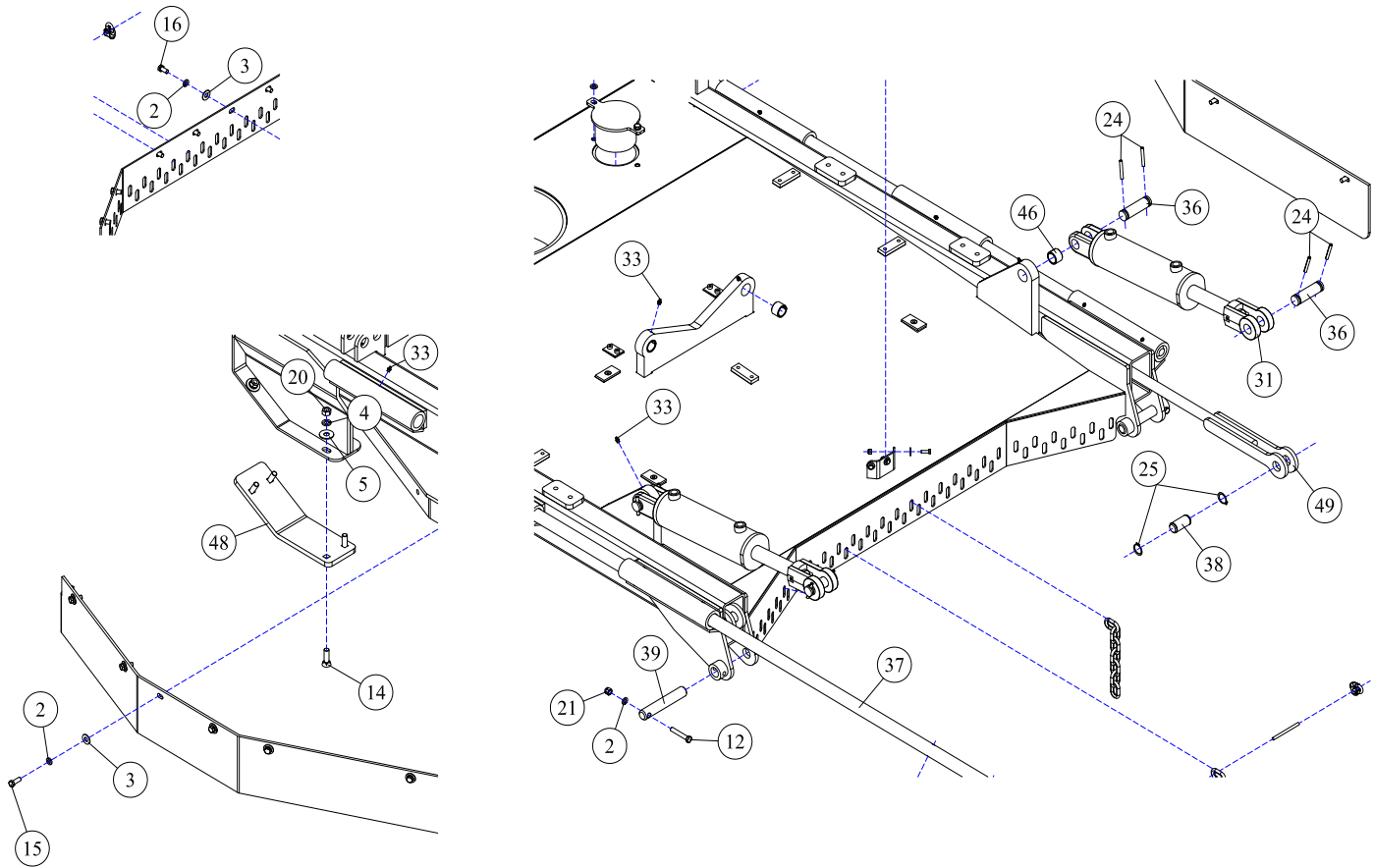

REF#	PARTS DESCRIPTION	REQ	PART #
1	7/16 LOCK WASHER	2	11-0003
2	3/8 LOCK WASHER	30	11-0005
3	3/8 FLAT WASHER	26	11-0009
4	1/2 LOCK WASHER	8	11-0011
5	1/2 FLAT WASHER	8	11-0018
6	1/4 FLAT WASHER	5	11-0023
7	5/8 H.S. LOCK WASHER	12	11-0043
8	1/4 X 3/4 NC HEX CAP	9	11-0588
9	1-1/8 H.S. FLAT WASHER	3	11-0057
10	5/8 X 2 H.S. NF HEX CAPSCREW	6	11-0508
11	7/16 X 3-1/4 NC HEX CAPSCREW	2	11-0510
12	3/8 X 2-1/4 NC HEX CAPSCREW	2	11-0513
13	5/8 X 2-1/2 H.S. NF HEX CAPSCREW	6	11-0525
14	1/2 X 1-3/4 NC PLOW BOLT	8	11-0530
15	3/8 X 1 NC HEX CAPSCREW	16	11-0532
16	3/8 X 3/4 NC HEX CAPSCREW	12	11-0545
17	1/4 NC NYLOCK NUT	9	11-1022
18	BLADE BOLT - HEX BASE	3	11-0759
19	7/16 NC NYLOCK NUT	2	11-1003
20	1/2 NC HEX NUT	8	11-1016
21	3/8 NC NYLOCK NUT	2	11-1024
22	KNIFE MOUNTING NUT	3	11-1050
23	5/8 H.S. NF STOVER NUT	6	11-1143
24	1/4 X 2 ROLLPIN	11	11-2005
25	1" EXTERNAL SNAP-RING	8	11-2048
26	3/8 X 2 ROLLPIN	4	11-2050
27	1/4 GALVANIZED CABLE, SOLD/FT	20 ft	12-0032
28	CABLE CLAMP	4	12-0033

REF#	PARTS DESCRIPTION	REQ	PART #
29	5/16" X 6 LINK, GR 30	51	12-0035
30	5/16" X 7 LINK, GR 30	51	12-0036
31	3 X 8 CYLINDER, REPHASING	2	14-0041
32	HIGH SUCTION 60" KNIFE	3	22-0004
33	GREASE ZERK	10	23-0004
34	BOLT PROTECTOR	1	24-0004
35	DISK	1	24-0129
36	CYLINDER PIN	4	27-0004
37	HINGE PIN	2	27-0023
38	LIFT PIN	4	27-0026
39	BASE PIN	2	27-0029
40	HITCH PIN	2	27-0030
41	MOTOR	1	30-0518
42	CHAIN BRACKET	1	31-0171
43	SMV BRACKET	1	31-0173
44	LEFT SHROUD	1	31-0188
45	RIGHT SHROUD	1	31-0189
46	BUSHING	4	34-0005
47	SPINDLE	1	35-0088
48	SKID SHOE	2	42-0029
49	LIFT ROD	2	49-6026
50	LIFT ROD END	2	49-6027
51	CENTER SECTION	1	49-6045
52	ACCESS PORT COVER	1	80-3507
53	SMV SIGN	1	90-8018
54	MOTOR BOLT LOCK TAB	4	31-0503
55	MOTOR BOLT LOCK BASE	2	31-0504
56	1/2-20 X 1-3/4 H.S. NF HEX CAP GR.8	4	11-0664

FRAME ASSEMBLIES - RIGHT WING, 15'/10' GEAR BOX DRIVE

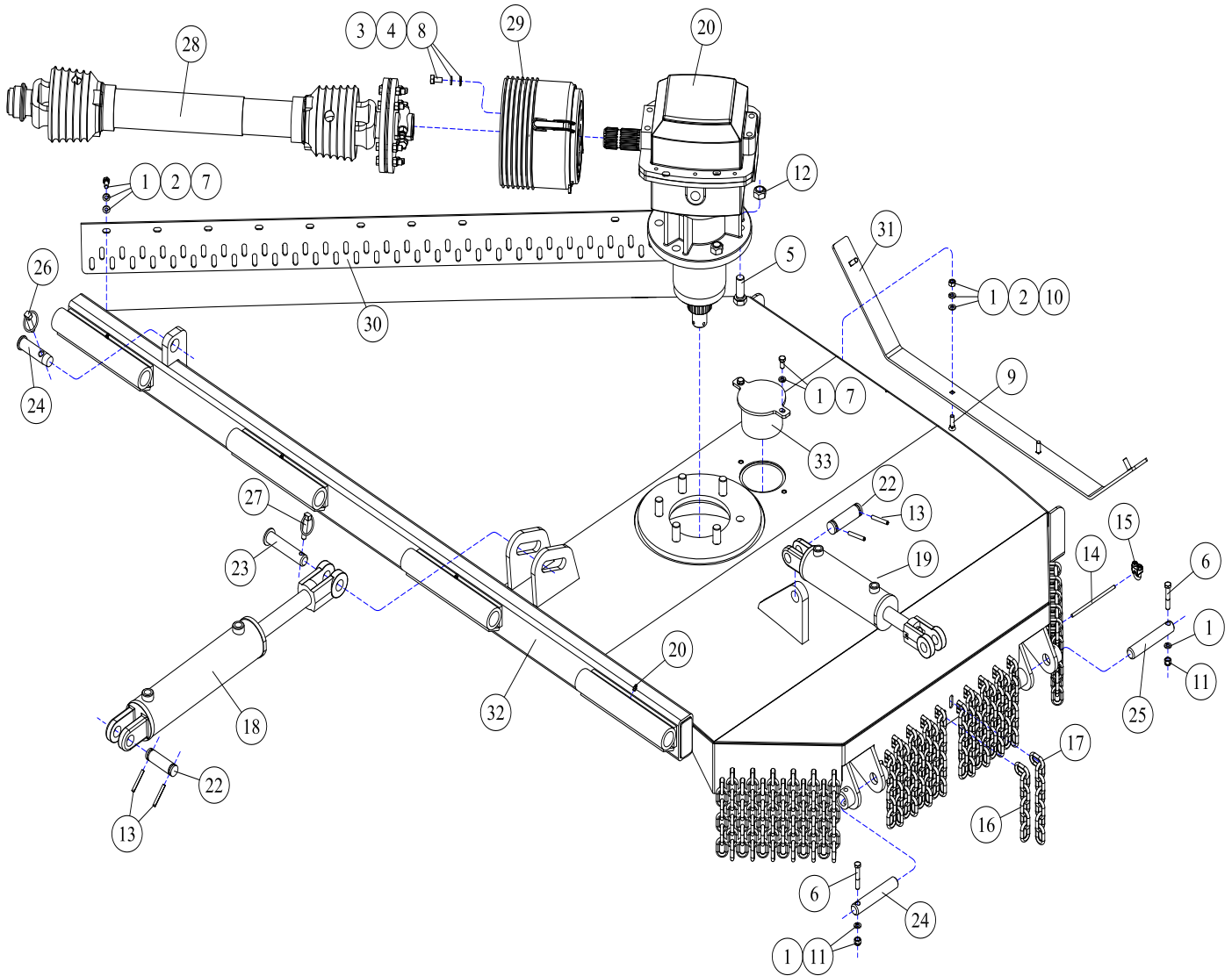

REF#	PARTS DESCRIPTION	REQ	PART #
1	3/8 LOCK WASHER	24	11-0005
2	5/16 FLAT WASHER	20	11-0015
3	10MM LOCK WASHER	4	11-0032
4	10MM FLAT WASHER	4	11-0065
5	3/4 X 2-1/4 H.S. NF HEX CAPSCREW	6	11-0658
6	3/8 X 2-1/4 NC HEX CAPSCREW	2	11-0513
7	3/8 X 3/4 NC HEX CAPSCREW	17	11-0545
8	10MM X 20MM X 1.5 NC HEX CAPSCREW	4	11-0721
9	3/8 X 1-1/4 NC PLOW BOLT	5	11-0804
10	3/8 NC HEX NUT	5	11-1001
11	3/8 NC NYLOCK NUT	2	11-1024
12	3/4 H.S. NF STOVER NUT	6	11-1032
13	1/4 X 2 ROLL PIN	4	11-2005
14	1/4 GALVANIZED CABLE	Avail/ft	12-0032
15	CABLE CLAMP	4	12-0033
16	5/16" X 6 LINK, GR 30	52	12-0035
17	5/16" X 7 LINK, GR 30	53	12-0036

REF#	PARTS DESCRIPTION	REQ	PART #
18	3 X 10 CYLINDER	1	14-0001
19	2.8 X 8 CYLINDER	1	14-0040
20	GEARBOX, 1000 RPM	1	19-0081
21	GREASE ZERK	4	23-0004
22	CLEVIS PIN	2	27-0004
23	CYLINDER PIN	1	27-0009
24	TRANSPORT LOCK PIN	1	27-0015
25	WING/CASTER PIN	2	27-0029
26	7/16 X 2 LYNCH PIN	1	27-1005
27	5/16 X 1-9/16 LYNCH PIN	1	27-1028
28	DRIVE LINE	1	29-0049
29	INPUT CONNECTION SHIELD	1	29-0052
30	CHAIN BRACKET	1	31-0170
31	SKID SHOE	1	42-0028
32	RIGHT WING	1	49-6042
33	ACCESS PORT COVER	1	80-3507

FRAME ASSEMBLIES - RIGHT WING, 15'/10' HYDRAULIC DRIVE

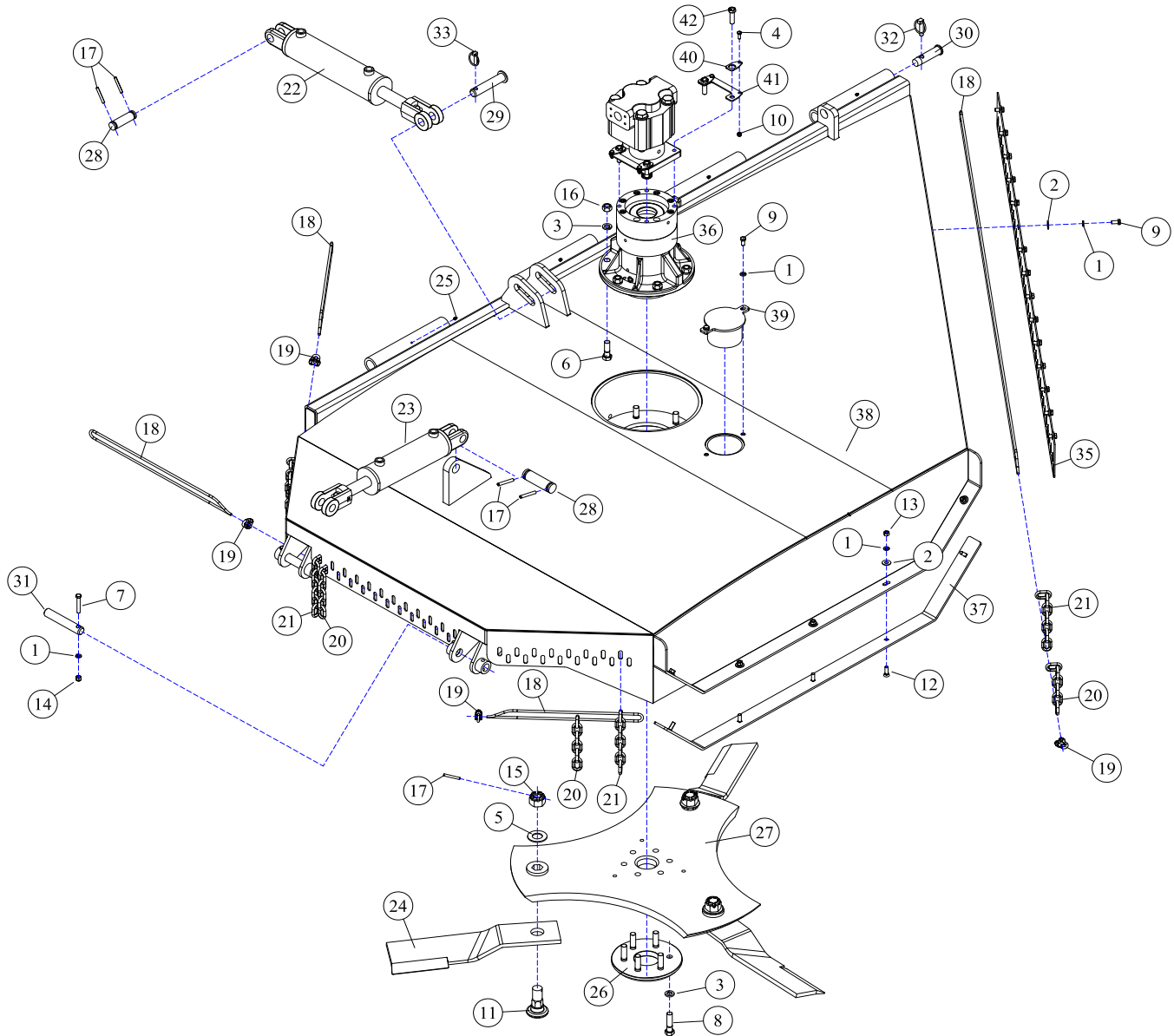

REF#	PARTS DESCRIPTION	REQ	PART #
1	3/8 LOCK WASHER	24	11-0005
2	3/8 FLAT WASHER	20	11-0009
3	5/8 H.S. LOCK WASHER	12	11-0043
4	1/4 X 3/4 NC HEX CAP	4	11-0588
5	1-1/8 H.S. FLAT WASHER	3	11-0057
6	5/8 X 2 H.S. NF HEX CAPSCREW	6	11-0508
7	3/8 X 2-1/4 NC HEX CAPSCREW	2	11-0513
8	5/8 X 2-1/2 H.S. NF HEX CAPSCREW	6	11-0525
9	3/8 X 3/4 NC HEX CAPSCREW	17	11-0545
10	1/4 NC NYLOCK NUT	4	11-1022
11	BLADE BOLT - HEX BASE	3	11-0759
12	3/8 X 1-1/4 NC PLOW BOLT	5	11-0804
13	3/8 NC HEX NUT	5	11-1001
14	3/8 NC NYLOCK NUT	2	11-1024
15	KNIFE MOUNTING NUT	3	11-1050
16	5/8 H.S. NF STOVER NUT	6	11-1143
17	1/4 X 2 ROLL PIN	7	11-2005
18	1/4 GALVANIZED CABLE, SOLD/FT	24 ft	12-0032
19	CABLE CLAMP	4	12-0033
20	5/16" X 6 LINK, GR 30	65	12-0035
21	5/16" X 7 LINK, GR 30	65	12-0036

REF#	PARTS DESCRIPTION	REQ	PART #
22	3 X 10 CYLINDER	1	14-0001
23	2.8 X 8 CYLINDER	1	14-0040
24	HIGH SUCTION BLADE - REVERSE	3	22-0014
25	GREASE ZERK	4	23-0004
26	BOLT PROTECTOR	1	24-0004
27	DISK	1	24-0086
28	CLEVIS PIN	2	27-0004
29	CYLINDER PIN	1	27-0009
30	HINGE PIN	1	27-0015
31	WING/CASTER PIN	2	27-0029
32	LYNCH PIN (LARGE)	1	27-1005
33	LYNCH PIN (SMALL)	1	27-1028
34	MOTOR	1	30-0524
35	CHAIN BRACKET	1	31-0170
36	SPINDLE	1	35-0088
37	SKID SHOE	1	42-0028
38	RIGHT WING SECTION	1	49-6046
39	ACCESS PORT COVER	1	80-3507
40	MOTOR BOLT LOCK TAB	4	31-0503
41	MOTOR BOLT LOCK BASE	2	31-0504
42	1/2-20 X 1-3/4 H.S. NF HEX CAP GR.8	4	11-0664

FRAME ASSEMBLIES - LEFT SKIRT/COUNTER WEIGHT, 10' FLEXWINGS

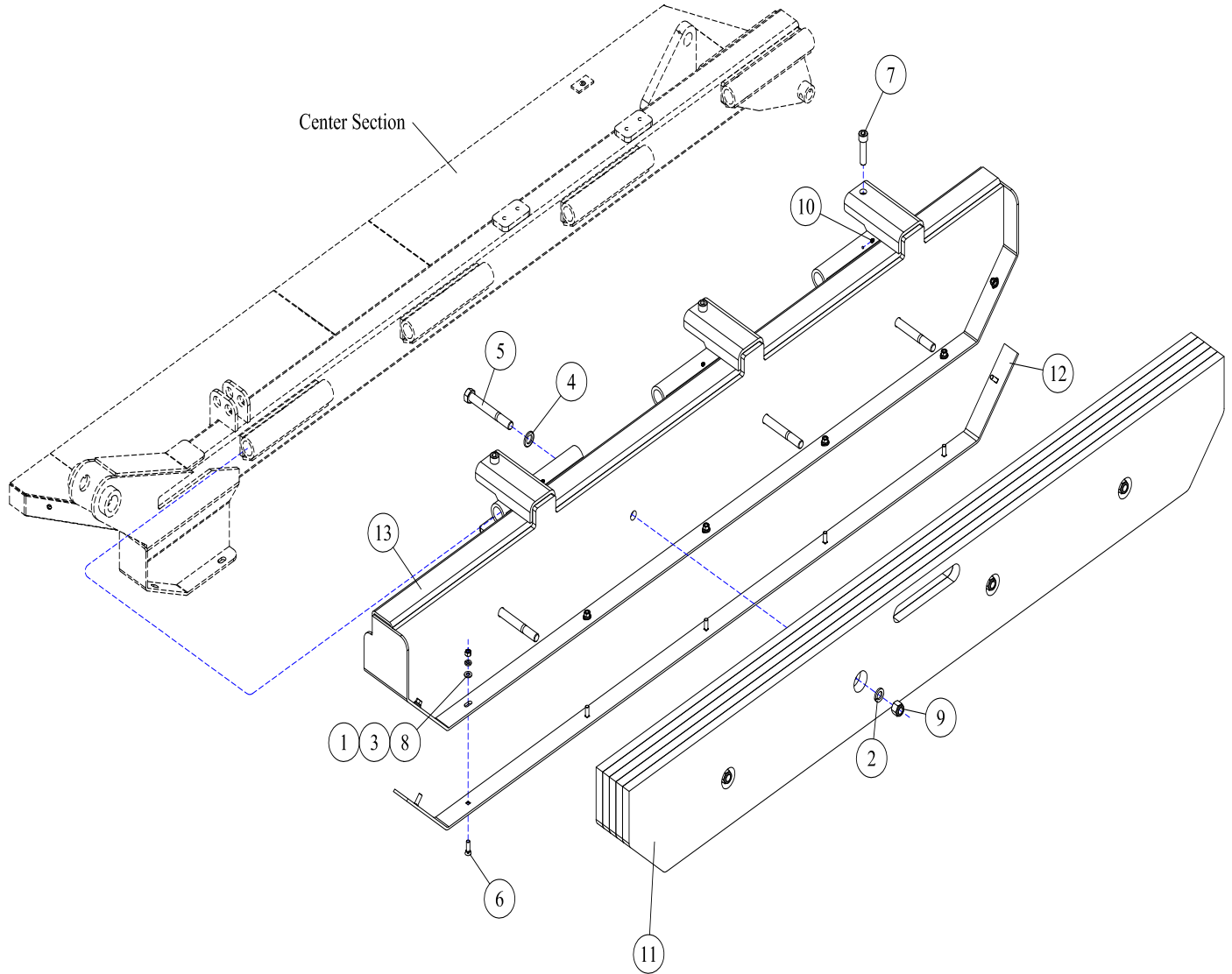

REF#	PARTS DESCRIPTION	REQ	PART #
1	3/8 LOCK WASHER	7	11-0005
2	3/4 LOCK WASHER	4	11-0007
3	3/8 FLAT WASHER	7	11-0009
4	3/4 H.S. SAE FLAT WASHER	4	11-0039
5	3/4 X 6 NC HEX CAPSCREW	4	11-0717
6	3/8 X 1-1/4 NC PLOW BOLT	7	11-0804
7	5/8 X 2-1/4 NC SOCKET HEAD CAPSCREW	3	11-0856

REF#	PARTS DESCRIPTION	REQ	PART #
8	3/8 NC HEX NUT	7	11-1001
9	3/4 NC NYLOCK NUT	4	11-1006
10	GREASE ZERK 1/4" STRAIGHT	3	23-0004
11	COUNTERWEIGHT	1	40-0092
12	SKID SHOE	1	42-0031
13	LEFT SKIRT	1	49-6044

FRAME ASSEMBLIES - HITCH ASSEMBLY, 15'/10' FLEXWINGS

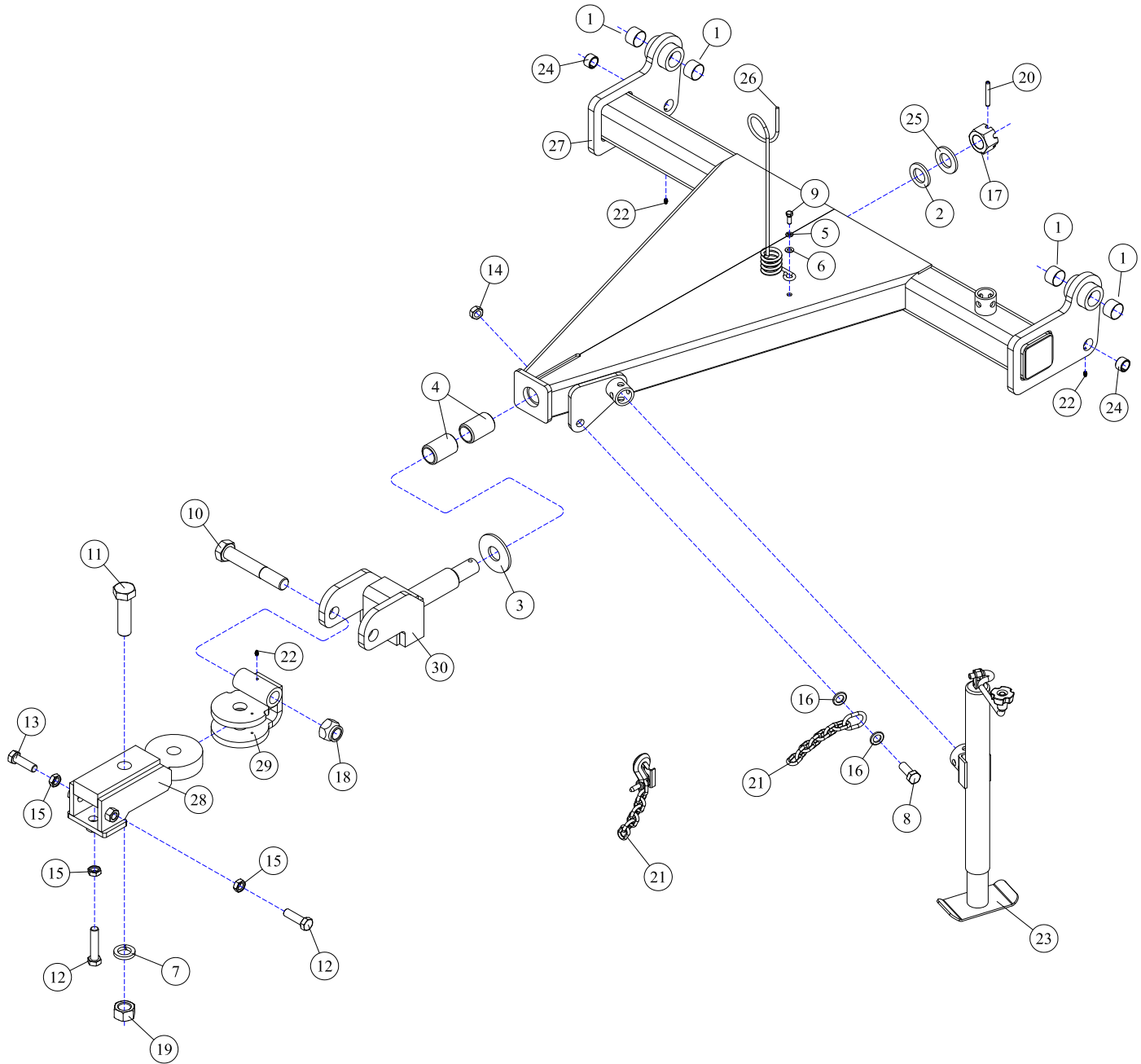

Parts 6, 10, 11, 12, 14 & 18 must be purchased together using kit 11-3017.

REF#	PARTS DESCRIPTION	REQ	PART #
1	GREASELESS BUSHING BEARING	4	10-0064
2	NYLON BUSHING	1	10-0045
3	NYLATORON BEARING	1	10-0051
4	GREASELESS BUSHING BEARING	2	10-0074
5	3/8 LOCK WASHER	1	11-0005
6	3/8 FLAT WASHER	1	11-0009
7	1-1/4 LOCK WASHER	1	11-0073
8	3/4 X 2 H.S. NF HEX CAPSCREW	1	11-0507
9	3/8 X 1 NC HEX CAPSCREW	1	11-0532
10	1-1/4 X 7-1/2 H.S. NC HEX CAPSCREW	1	11-0794
11	1-1/4 X 4-1/2 H.S. NC HEX CAPSCREW	1	11-0860
12	3/4 X 3-1/2 H.S. NC HEX CAPSCREW	1	11-0861
13	3/4 X 2-1/2 H.S. NC HEX CAPSCREW	1	11-0862
14	3/4 H.S. NF STOVER NUT	1	11-1032
15	3/4 NC JAM NUT	3	11-1034

REF#	PARTS DESCRIPTION	REQ	PART #
16	3/4 H.S. SAE FLAT WASHER	2	11-1039
17	1-1/2 UNF HEX SLOTTED NUT	1	11-1052
18	1-1/4 NC TOP LOCK NUT	1	11-1056
19	1-1/4 HEX HEX NUT	1	11-1066
20	3/16 X 3 COTTER PIN	1	27-1030
21	SAFETY CHAIN	1	12-0053
22	GREASE ZERK	3	23-0004
23	JACK	1	24-0119
24	BUSHING, 1-1/4 OD X 1 ID X 3/4	2	34-0119
25	HITCH SPACER RING	1	34-0122
26	SPRING HOSE LOOP	1	36-0006
27	LIFT HITCH	1	49-6017
28	HITCH ADAPTER	1	41-1010
29	HITCH BRACKET	1	41-1009
30	HITCH PIVOT	1	49-6050

CUTTER ASSEMBLIES



CUTTER ASSEMBLIES - TRI-HEX, 15'/10' GEAR BOX DRIVE

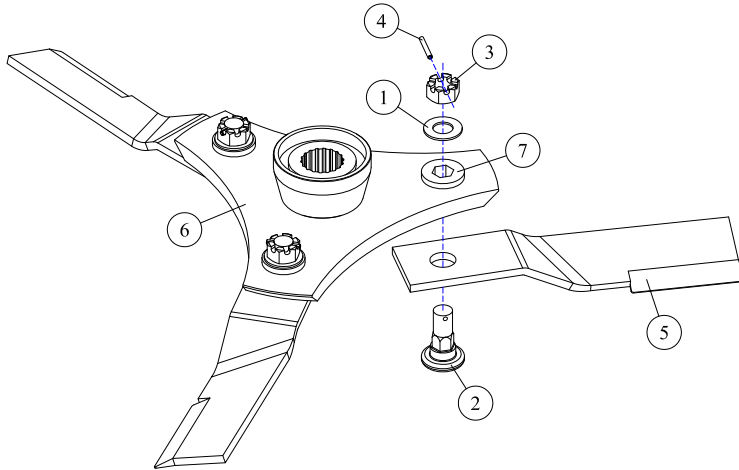

REF#	PARTS DESCRIPTION	REQ	PART #
1	1-1/8 SAE H.S. FLAT WASHER	3	11-0057
2	BLADE BOLT - HEX BASE	3	11-0759
3	1-1/2 NF CASTLE NUT	3	11-1050
4	1/4 X 2 ROLLPIN	3	11-2005
5	HIGH SUCTION KNIFE	3	22-0004
6	DISH	1	24-0116
7	REPLACEABLE INSERT	Avail	90-7010

Left wing cutter assembly is not required on 10' flexwings

Left wing standard rotation
(clockwise)

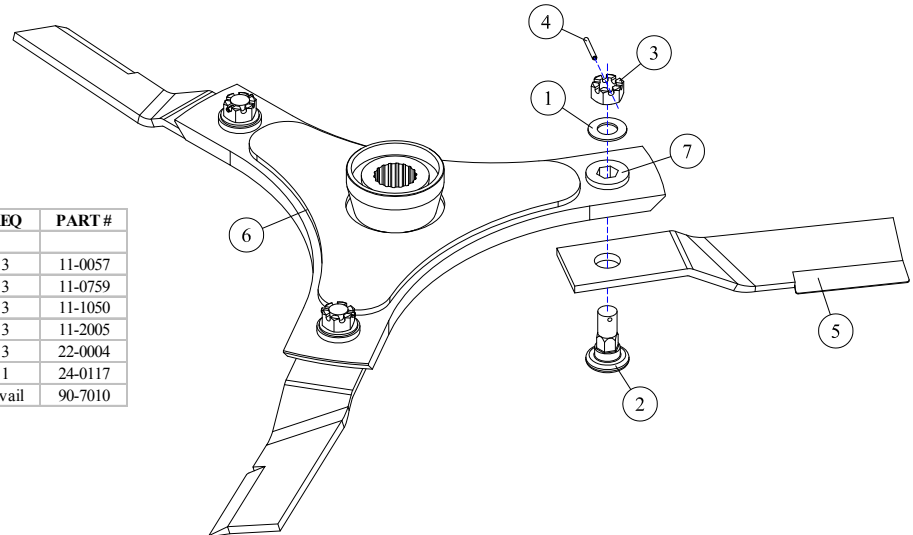

REF#	PARTS DESCRIPTION	REQ	PART #
1	1-1/8 SAE H.S. FLAT WASHER	3	11-0057
2	BLADE BOLT - HEX BASE	3	11-0759
3	1-1/2 NF CASTLE NUT	3	11-1050
4	1/4 X 2 ROLLPIN	3	11-2005
5	HIGH SUCTION KNIFE	3	22-0004
6	DISH	1	24-0117
7	REPLACEABLE INSERT	Avail	90-7010

Center section standard rotation
(clockwise)

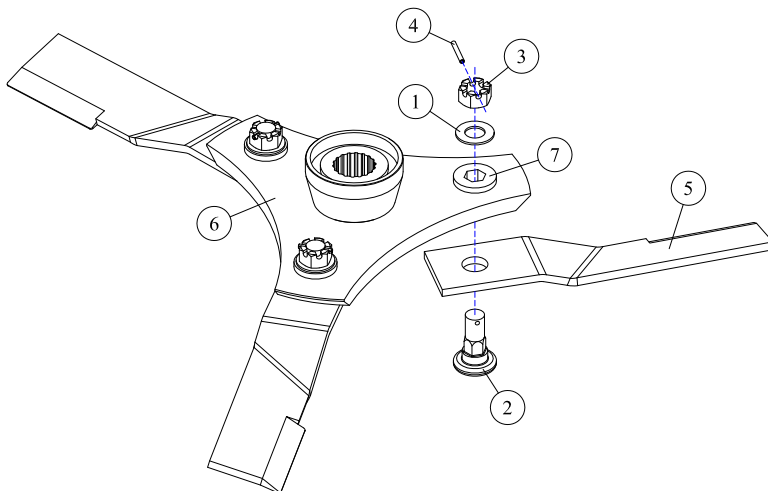

REF#	PARTS DESCRIPTION	REQ	PART #
1	1-1/8 SAE H.S. FLAT WASHER	3	11-0057
2	BLADE BOLT - HEX BASE	3	11-0759
3	1-1/2 NF CASTLE NUT	3	11-1050
4	1/4 X 2 ROLLPIN	3	11-2005
5	HIGH SUCTION KNIFE	3	22-0014
6	DISH	1	24-0116
7	REPLACEABLE INSERT	Avail	90-7010

Right wing reverse rotation
(counter clockwise)

CASTER ASSEMBLIES



CASTER ASSEMBLIES - CENTER ASSEMBLY, 15'/10' GEAR BOX/HYDRAULIC DRIVE

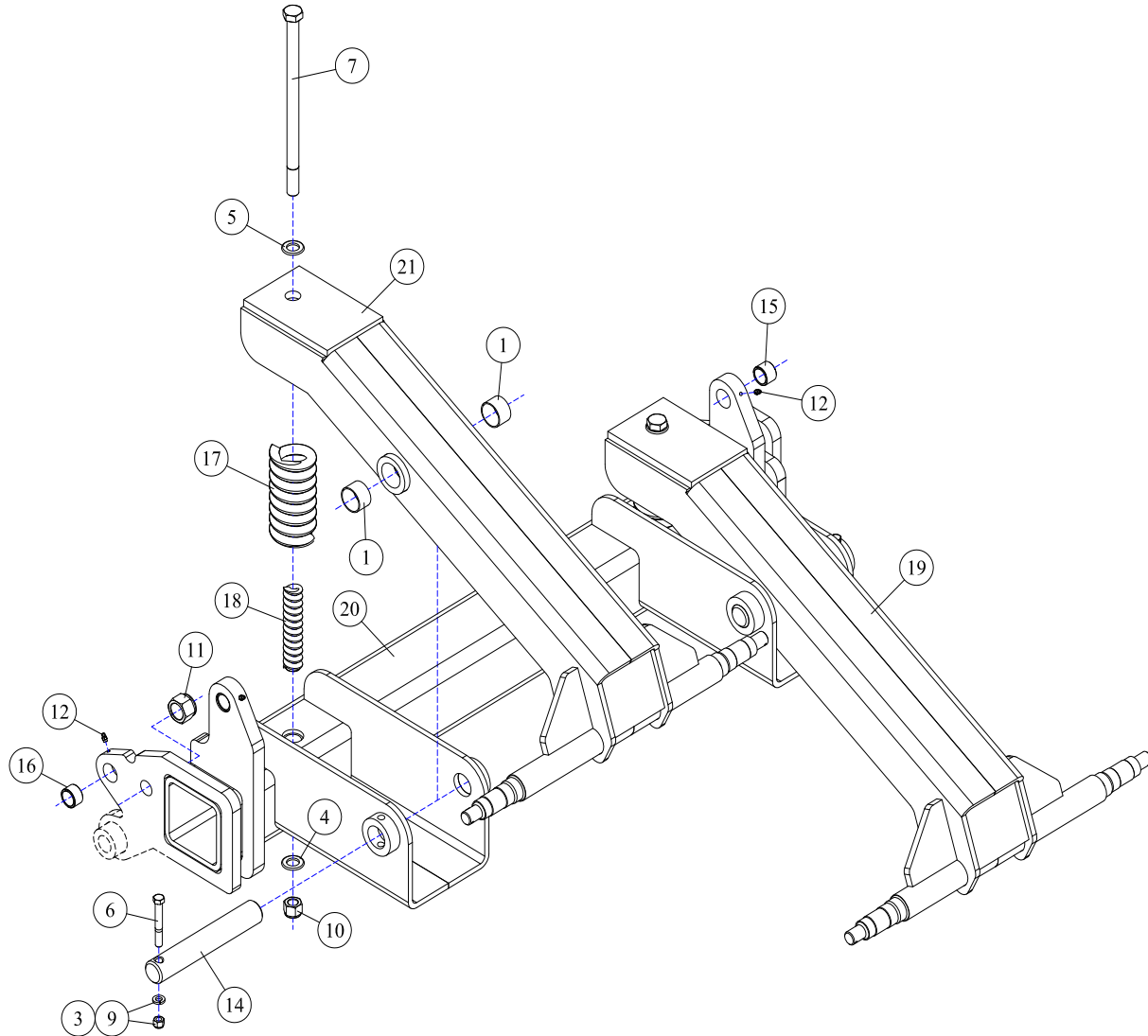

REF#	PARTS DESCRIPTION	REQ	PART #
1	GREASELESS BUSHING, 1-1/2"	4	10-0064
2	GREASELESS BUSHING, 1-1/8"	4	10-0065
3	7/16 LOCK WASHER	4	11-0003
4	3/4 FLAT WASHER	2	11-0010
5	3/4 H.S. SAE FLAT WASHER	2	11-0039
6	7/16 X 3-1/4 NC HEX CAPSCREW	4	11-0510
7	3/4 X 13 NC H.S. HEX CAPSCREW	2	11-0630
8	1 X 6-1/2 NC HEX CAPSCREW	2	11-0850
9	7/16 NC NYLOCK NUT	4	11-1003
10	3/4 NC NYLOCK NUT	2	11-1006
11	1 NC NYLOCK NUT	2	11-1063

REF#	PARTS DESCRIPTION	REQ	PART #
12	GREASE ZERK	4	23-0004
13	AXLE PIN	2	27-0024
14	CASTER PIN	2	27-0027
15	HARDENED BUSHING, 1"	2	34-0005
16	HARDENED BUSHING, 3/4"	2	34-0119
17	COIL SPRING, LARGE	2	36-0004
18	COIL SPRING, SMALL	2	36-0005
19	RIGHT CENTER CASTER	1	49-6056
20	CENTER CASTER	1	49-6057
21	LEFT CENTER CASTER	1	49-6058

CASTER ASSEMBLIES - RIGHT ASSEMBLY, 15'/10' GEAR BOX/HYDRAULIC DRIVE

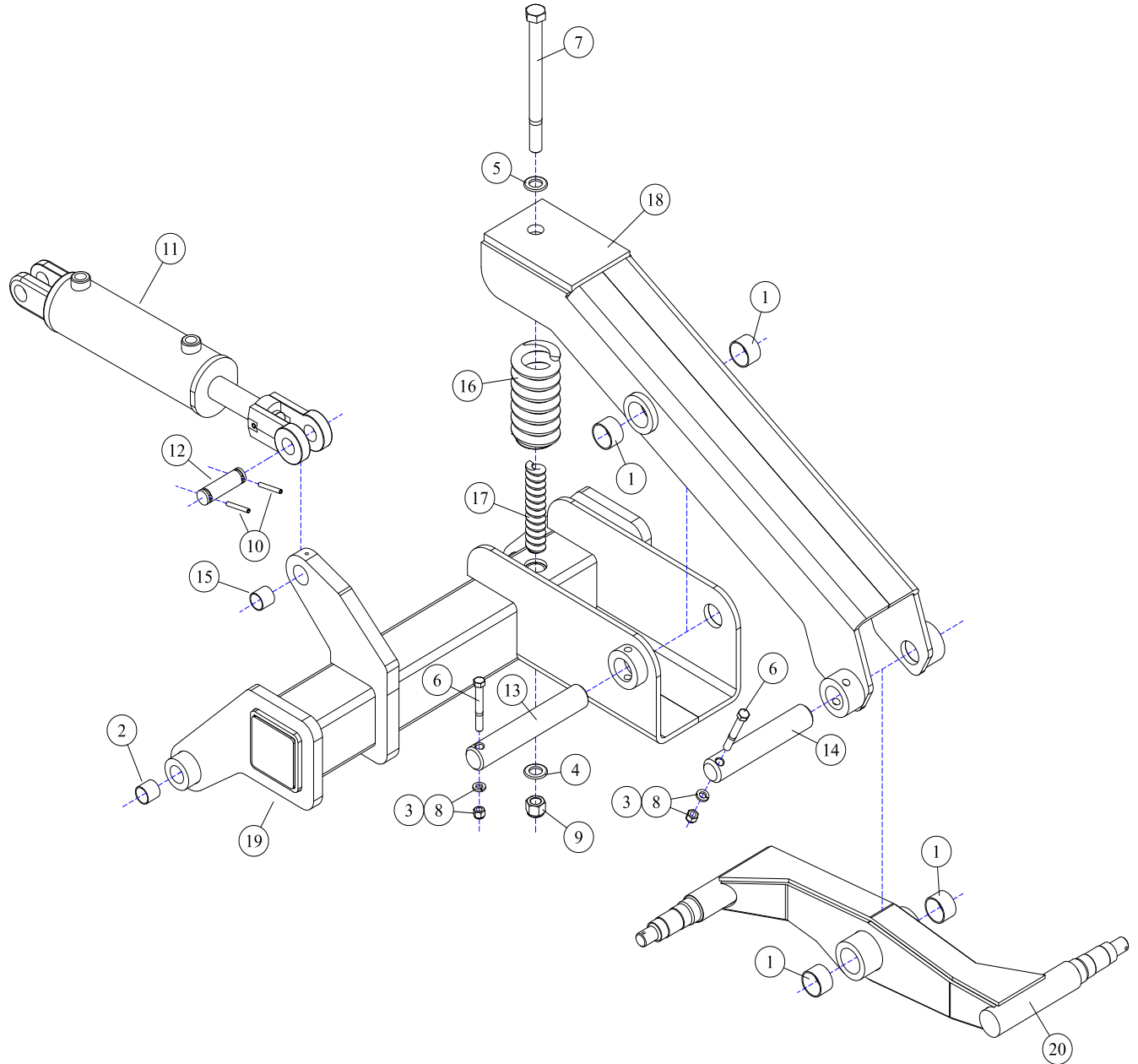

REF#	PARTS DESCRIPTION	REQ	PART #
1	GREASELESS BUSHING, 1-1/2"	4	10-0064
2	GREASELESS BUSHING, 1-1/8"	4	10-0065
3	7/16 LOCK WASHER	2	11-0003
4	3/4 FLAT WASHER	1	11-0010
5	3/4 H.S. SAE FLAT WASHER	1	11-0039
6	7/16 X 3-1/4 NC HEX CAPSCREW	2	11-0510
7	3/4 X 12 NC H.S. HEX CAPSCREW	1	11-0817
8	7/16 NC NYLOCK NUT	2	11-1003
9	3/4 NC NYLOCK NUT	1	11-1006
10	1/4 X 2 ROLL PIN	2	11-2005
11	2.8 X 8 CYLINDER	1	14-0040

REF#	PARTS DESCRIPTION	REQ	PART #
12	CLEVIS PIN	1	27-0004
13	CASTER LEG PIN	1	27-0024
14	CASTER PIN	1	27-0027
15	BUSHING 1-1/4 X 1 X 1	1	34-0005
16	COIL SPRING, LARGE	1	36-0004
17	COIL SPRING, SMALL	1	36-0005
18	CASTER LEG	1	49-6022
19	CASTER BRACKET	1	49-6054
20	STRUT/AXLE		
	STANDARD	1	49-6021
	EXTENDED (AIRPLANE TIRES)	1	49-6059

CASTER ASSEMBLIES - LEFT ASSEMBLY, 15'/10' GEAR BOX/HYDRAULIC DRIVE

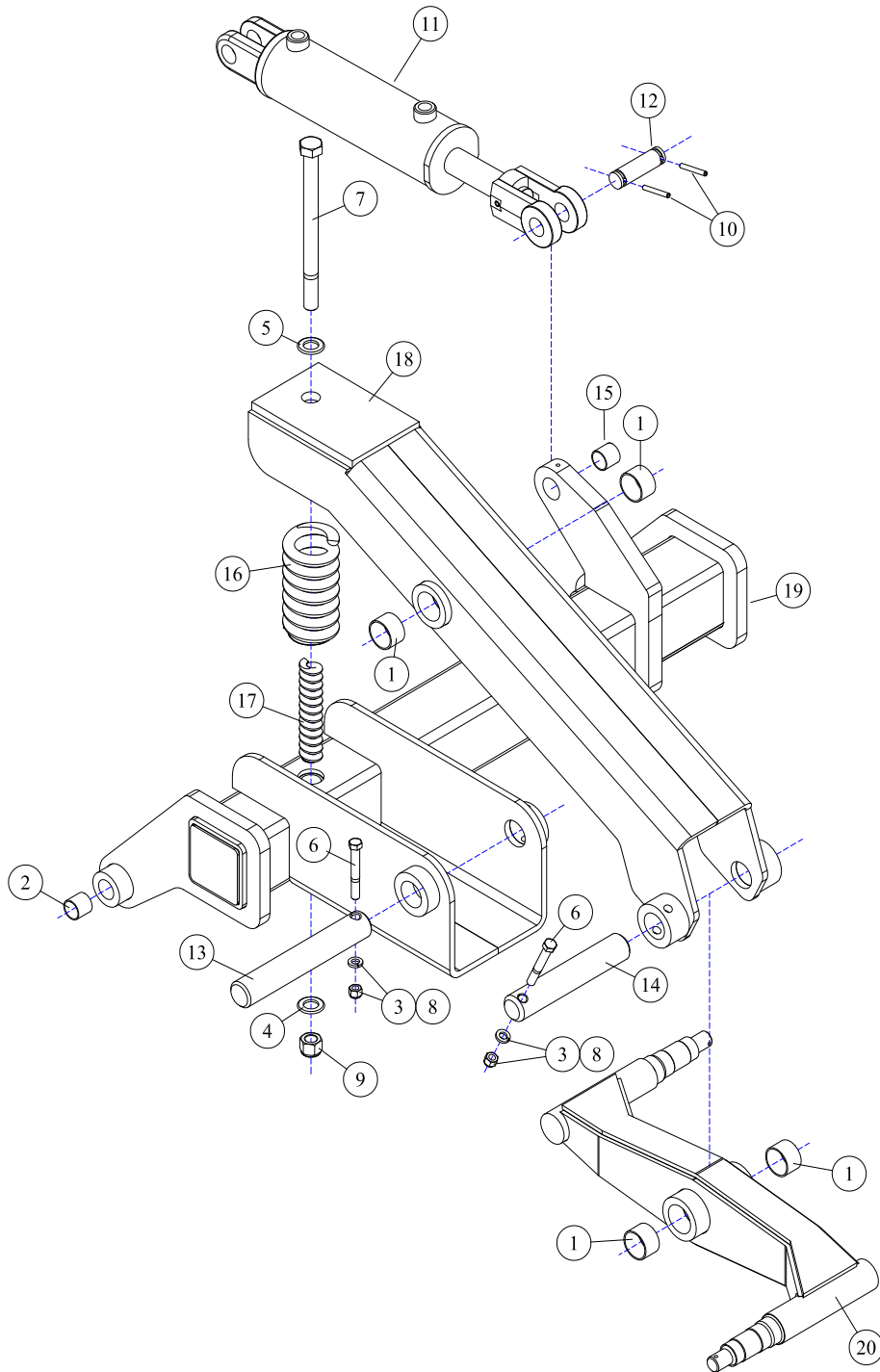

REF#	PARTS DESCRIPTION	REQ	PART #
1	GREASELESS BUSHING, 1-1/2"	4	10-0064
2	GREASELESS BUSHING, 1-1/8"	4	10-0065
3	7/16 LOCK WASHER	2	11-0003
4	3/4 FLAT WASHER	1	11-0010
5	3/4 H.S. SAE FLAT WASHER	1	11-0039
6	7/16 X 3-1/4 NC HEX CAPSCREW	2	11-0510
7	3/4 X 12 NC H.S. HEX CAPSCREW	1	11-0817
8	7/16 NC NYLOCK NUT	2	11-1003
9	3/4 NC NYLOCK NUT	1	11-1006
10	1/4 X 2 ROLL PIN	2	11-2005
11	2.8 X 8 CYLINDER	1	14-0040

REF#	PARTS DESCRIPTION	REQ	PART #
12	CLEVIS PIN	1	27-0004
13	CASTER LEG PIN	1	27-0024
14	CASTER PIN	1	27-0027
15	BUSHING 1-1/4 X 1 X 1	1	34-0005
16	COIL SPRING, LARGE	1	36-0004
17	COIL SPRING, SMALL	1	36-0005
18	CASTER LEG	1	49-6022
19	CASTER BRACKET	1	49-6055
20	STRUT/AXLE		
	STANDARD	1	49-6021
	EXTENDED (AIRPLANE TIRES)	1	49-6059

CASTER ASSEMBLIES - HUB/WHEEL ASSEMBLY

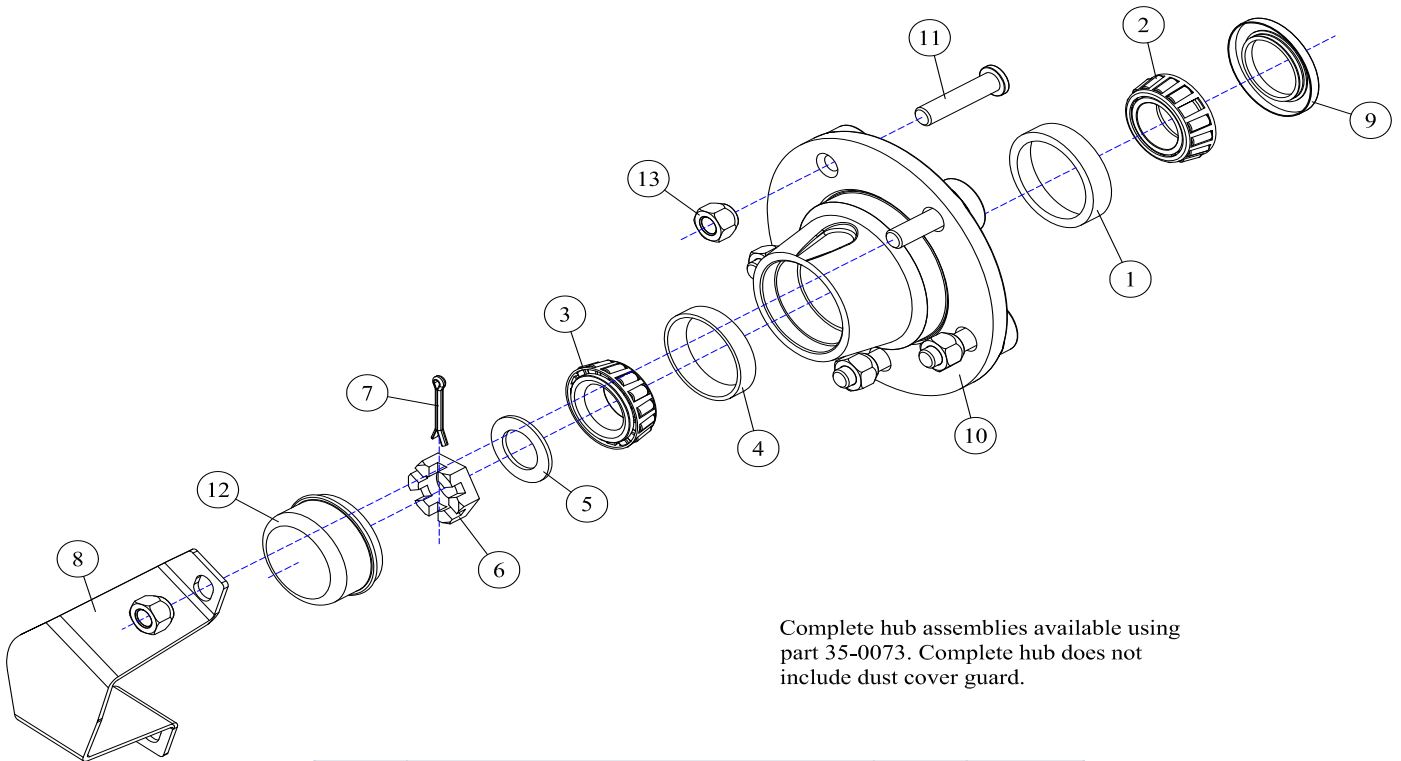

Complete hub assemblies available using part 35-0073. Complete hub does not include dust cover guard.

REF#	PARTS DESCRIPTION	REQ	PART #
1	1-3/8 BEARING CUP	1	10-0026
2	1-3/8 BEARING CONE	1	10-0027
3	1-1/4 BEARING CONE	1	10-0066
4	1-1/4 BEARING CUP	1	10-0067
5	7/8 SAE FLAT WASHER	1	11-0070
6	7/8-14 NF SLOTTED HEX NUT	1	11-1065
7	3/16 X 1-3/4 COTTER PIN	1	27-1029
8	DUST COVER GUARD	1	31-0182
9	SEAL, 1.50 X 2.623 X .250	1	33-0059
10	HUB	1	35-0067
11	STUD, PRESS-IN	5	35-0068
12	DUST CAP	1	35-0070
13	LUG NUT	5	35-0071

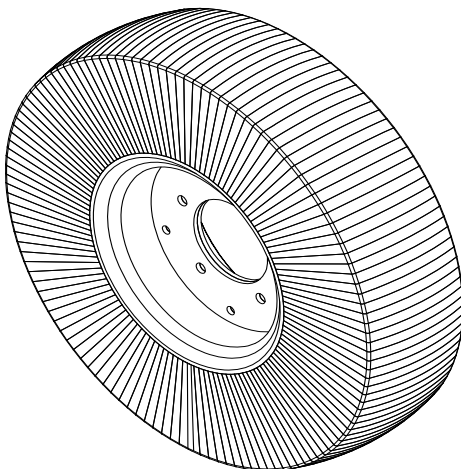

38-0007 Laminate Tire
(Obsolete part replaced with 38-0006)

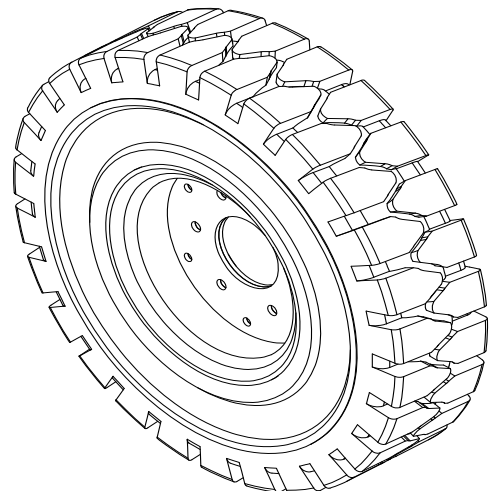

38-0006 Rubber Tire

HYDRAULIC ASSEMBLIES



HYDRAULIC SYSTEMS - HYDRAULIC ASSEMBLY, 10' HYDRAULIC FLEXWING

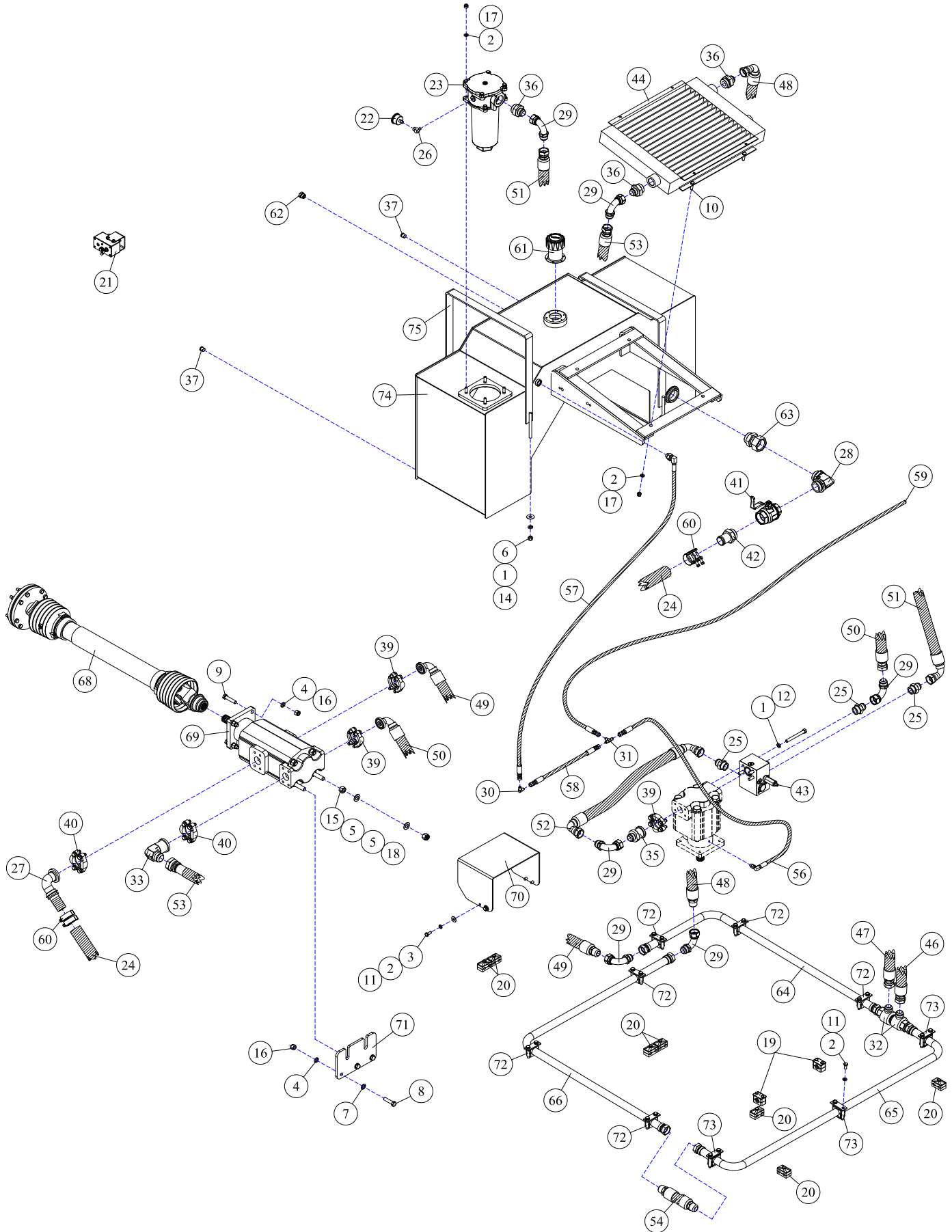

HYDRAULIC SYSTEMS - HYDRAULIC ASSEMBLY, 10' HYDRAULIC FLEXWING

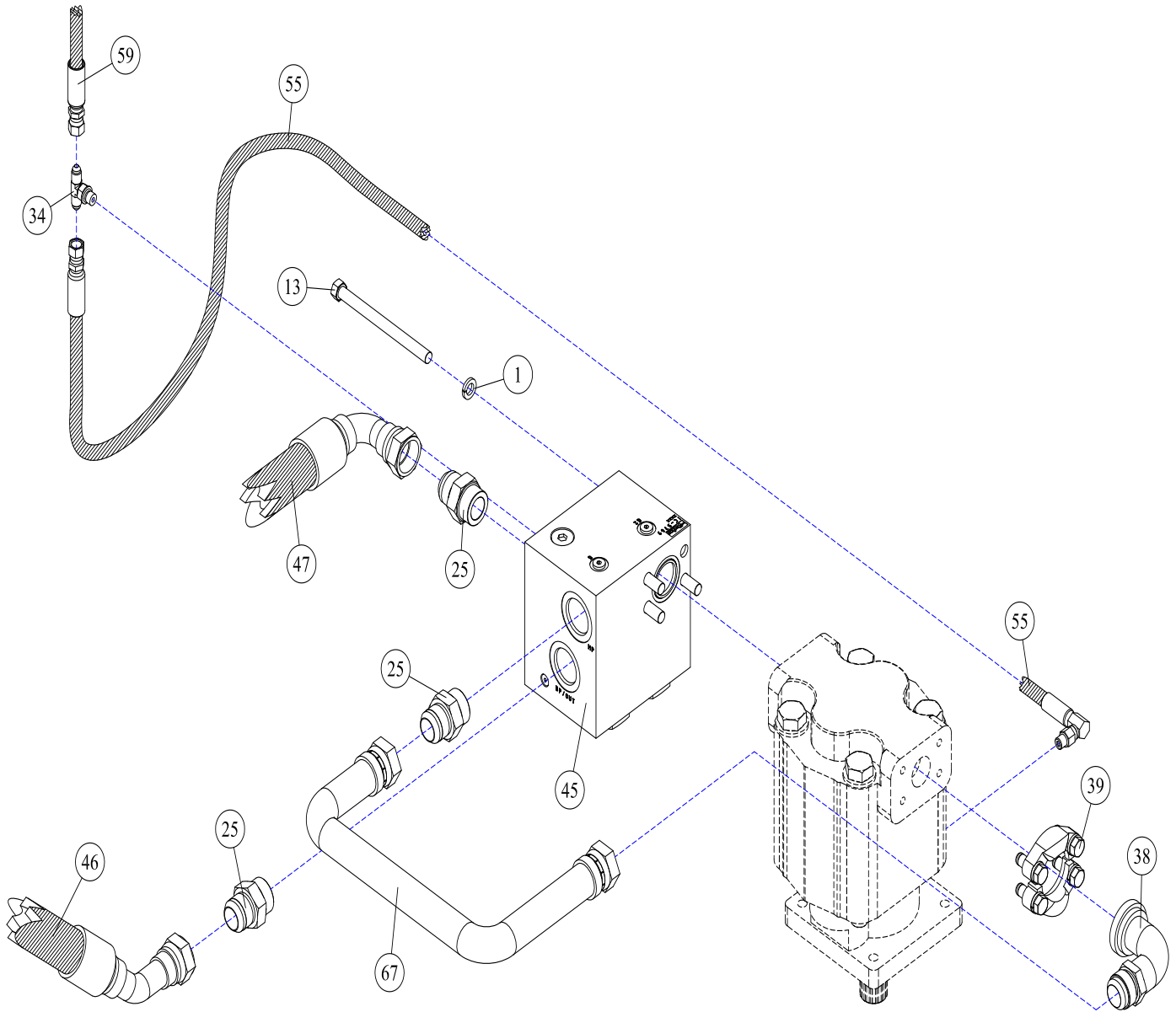

HYDRAULIC SYSTEMS - HYDRAULIC ASSEMBLY, 10' HYDRAULIC FLEXWING

REF#	PARTS DESCRIPTION	REQ	PART #
1	7/16 LOCK WASHER GR 5	12	11-0003
2	3/8 LOCK WASHER GR 5	30	11-0005
3	3/8 FLAT WASHER GR 5	4	11-0009
4	1/2 LOCK WASHER GR 5	7	11-0011
5	5/8 HS SAE FLAT WASHER	4	11-0012
6	7/16 FLAT WASHER GR 5	4	11-0024
7	1/2 SAE FLAT WASHER GR 8	3	11-0042
8	1/2 X 2 NC HEX CAPSCREW	3	11-0522
9	1/2 X 2-1/4 NC HEX CAPSCREW	4	11-0531
10	3/8 X 1-1/4 NC HEX CAPSCREW	4	11-0533
11	3/8 X 3/4 NC HEX CAPSCREW	22	11-0545
12	7/16 X 4 NC HEX CAPSCREW	4	11-0566
13	7/16 X 5-1/2 NC HEX CAPSCREW	4	11-0878
14	7/16 NC NYLOCK NUT	4	11-1003
15	5/8 NC HEX NUT	2	11-1004
16	1/2 NC NYLOCK NUT	7	11-1018
17	3/8 NC NYLOCK NUT	8	11-1024
18	5/8 NC NYLOCK NUT	2	11-1025
19	SINGLE 1/2" HOSE CLAMP	2	11-2041
20	DOUBLE 1/2" HOSE CLAMP	7	11-2047
21	SINGLE ROTARY SWITCH BOX	1	16-0003C
22	FILTER GAUGE	1	17-0003
23	FILTER ASSEMBLY IN TANK	1	17-0014
24	SUCTION HOSE	3	21-0001
25	1MOR X 1 MJIC, ADAPTER	6	21-1005
26	1/8 X 90DEG ELBOW	1	21-1104
27	FLANGE #24, 1-1/2 KING NIP 90DEG	1	21-1164
28	1-1/2 SAE MALE ADJ ELBOW	1	21-1232
29	1MJIC X 1 FJIC-90DEG, ADAPTER	6	21-1258
30	1/4MJIC X 1/4MJIC, ELBOW 90DEG	1	21-1262
31	1/4MJIC X 1/4MJIC X 1/4MJIC, TEE	1	21-1263
32	1MJIC X 1 MJIC-90DEG, LIVE SWIVEL	2	21-1269
33	#24 FLG X 1-1/4 MJIC-90DEG, ADAPTER	1	21-1270
34	1/4MJ X 1/4MJ X 1/4MOR, TEE	1	21-1271
35	1MJIC X #20 FLANGE, ADAPTER	1	21-1279
36	1MJIC X 1-1/4 MORB, ADAPTER	3	21-1477
37	#8 MORB HOLLOW HEX PLUG	2	21-1478
38	#20 FLG X 1MJIC-90DEG, ADAPTER	1	21-1529

REF#	PARTS DESCRIPTION	REQ	PART #
39	#20 FLANGE KIT	4	21-2105
40	#24 FLANGE KIT	2	21-2136
41	BALL VALVE, 1-1/2 SAE	1	21-2182
42	KING NIPPLE LONG, 1-1/2 SAE	1	21-2183
43	CENTER MOTOR MANIFOLD	1	21-2193
44	OIL COOLER AND FAN ASSEMBLY	1	21-2194
45	RIGHT HAND MOTOR MANIFOLD	1	21-2196
46	HOSE 1 X 40 (1FJIC-45DEG X 1FJIC)	1	21-3674
47	HOSE 1 X 45 (1FJIC-90DEG X 1FJIC)	1	21-3675
48	HOSE 1 X 22 (1FJIC-90DEG X 1MJIC)	1	21-3676
49	HOSE 1 X 12 (#20FLG-90DEG X 1MJIC)	1	21-3677
50	HOSE 1 X 25 (#20FLG-90DEG X 1FJIC)	1	21-3678
51	HOSE 1 X 61 (1FJIC-90DEG X 1FJIC)	1	21-3679
52	HOSE 1 X 13-1/2 (1FJIC-90DEG X 1FJIC-90DEG)	1	21-3680
53	HOSE 1 X 35 (1FJIC X 1-1/4FJIC)	1	21-3681
54	HOSE 1 X 5.375 (1MJIC X 1MJIC)	1	21-3902
55	HOSE 1/4 X 19 (1/4MORB-90DEG X 1/4FJIC)	1	21-4017
56	HOSE 1/4 X 33 (1/4MORB-90DEG X 1/4FJIC)	1	21-4018
57	HOSE 1/4 X 26 (1/2MORB-90DEG X 1/4FJIC)	1	21-4019
58	HOSE 1/4 X 10 (1/4FJIC X 1/4FJIC)	1	21-4020
59	HOSE 1/4 X 110 (1/4FJIC X 1/4FJIC)	1	21-4022
60	BANDIT CLAMP	4	24-0014
61	FILL SPOUT	1	24-0042
62	SAE SIGHT GLASS	1	24-0094
63	3 INCH TUBE EXTENSION	1	28-0047
64	PREFORMED TUBE (PRESSURE)	1	28-0053
65	PREFORMED TUBE (CROSSOVER)	1	28-0054
66	PREFORMED TUBE (RETURN)	1	28-0055
67	RUN-AROUND TUBE	1	28-0059
68	DRIVE LINE	1	29-0098
69	TANDEM PUMP	1	30-0017
70	PTO SHAFT GUARD	1	31-0098
71	PUMP SUPPORT PLATE	1	31-0236
72	TUBE CLAMP (SHORT)	6	44-0003
73	TUBE CLAMP (TALL)	3	44-0015
74	HYDRAULIC OIL TANK	1	47-0073
75	TANK STRAP	2	47-0530

HYDRAULIC SYSTEMS - REPHASING HEIGHT CONTROL, 10' FLEXWING

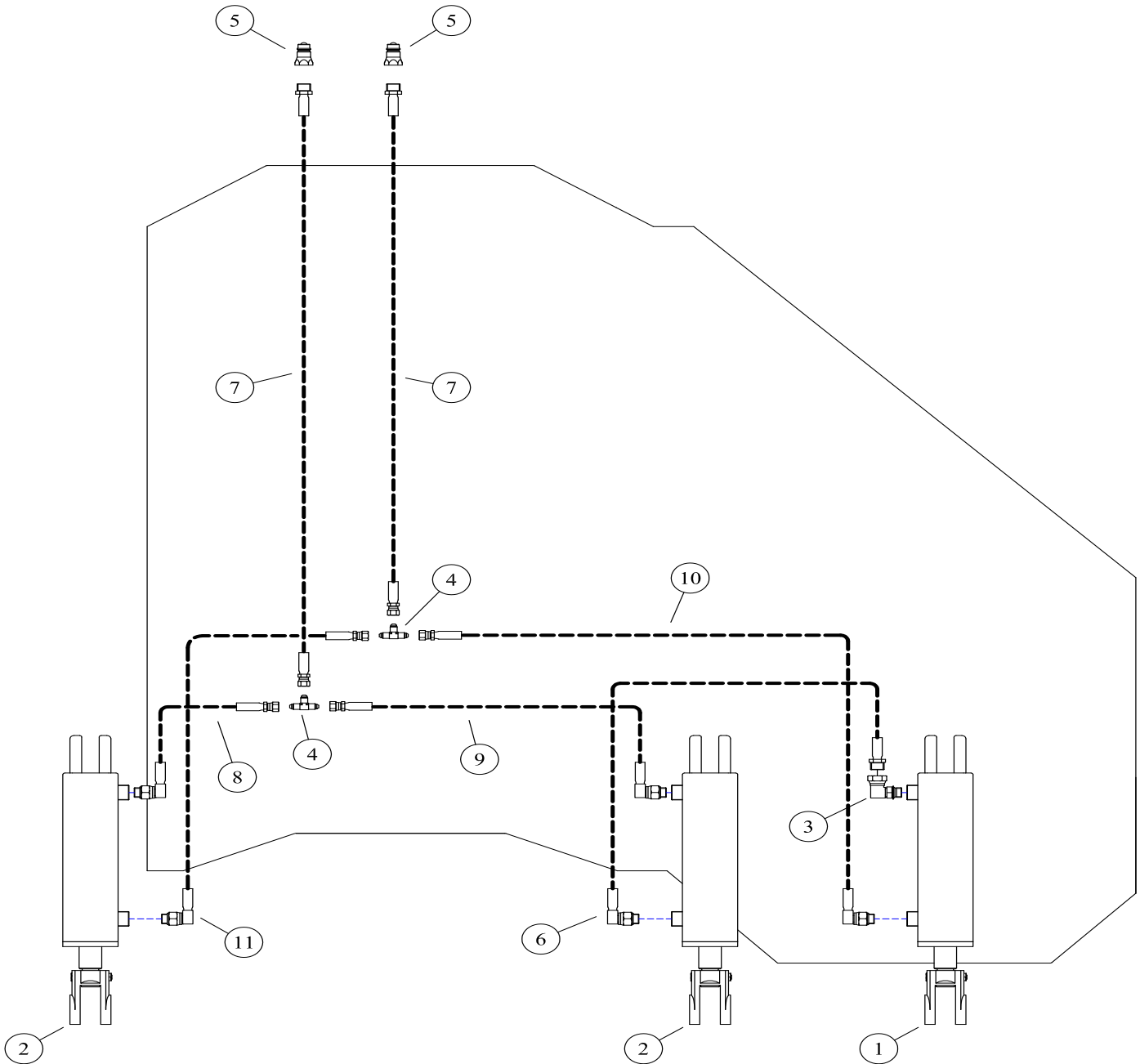

REF#	PARTS DESCRIPTION	REQ	PART #
1	2.8 X 8 CYLINDER, REPHASING	1	14-0040
2	3 X 8 CYLINDER, REPHASING	2	14-0041
3	1/2MORB X 1/2FPX-90DEG, ADAPTER	1	21-1119
4	1/4MJIC TEE	2	21-1263
5	1/2 MALE QUICK COUPLER	2	21-2119
6	HOSE 1/4 X 72 (1/2MORB-90DEG X 1/2MP)	1	21-2209
7	HOSE 1/4 X 190 (1/2MP X 1/4FJIC)	2	21-2470
8	HOSE 1/4 X 24 (1/2MORB-90DEG X 1/4FJIC)	1	21-4148
9	HOSE 1/4 X 43 (1/2MORB-90DEG X 1/4FJIC)	1	21-4149
10	HOSE 1/4 X 94 (1/2MORB-90DEG X 1/4FJIC)	1	21-4150
11	HOSE 1/4 X 32 (1/2MORB-90DEG X 1/4FJIC)	1	21-4152

HYDRAULIC SYSTEMS - WING LIFT CONTROL, 10' FLEXWING

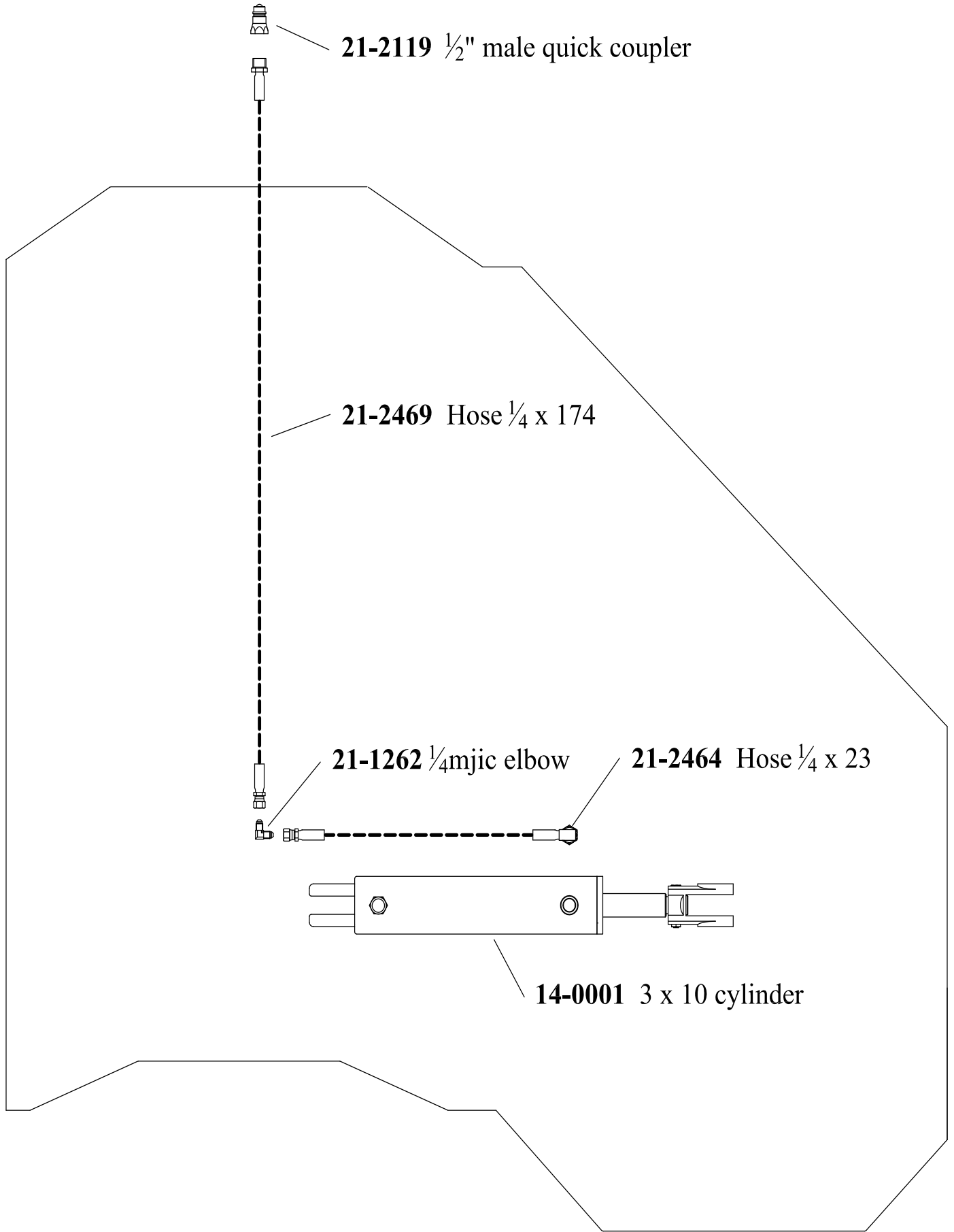

ELECTRICAL ASSEMBLIES



ELECTRICAL ASSEMBLIES - 10' HYDRAULIC FLEXWING, SCHEMATIC

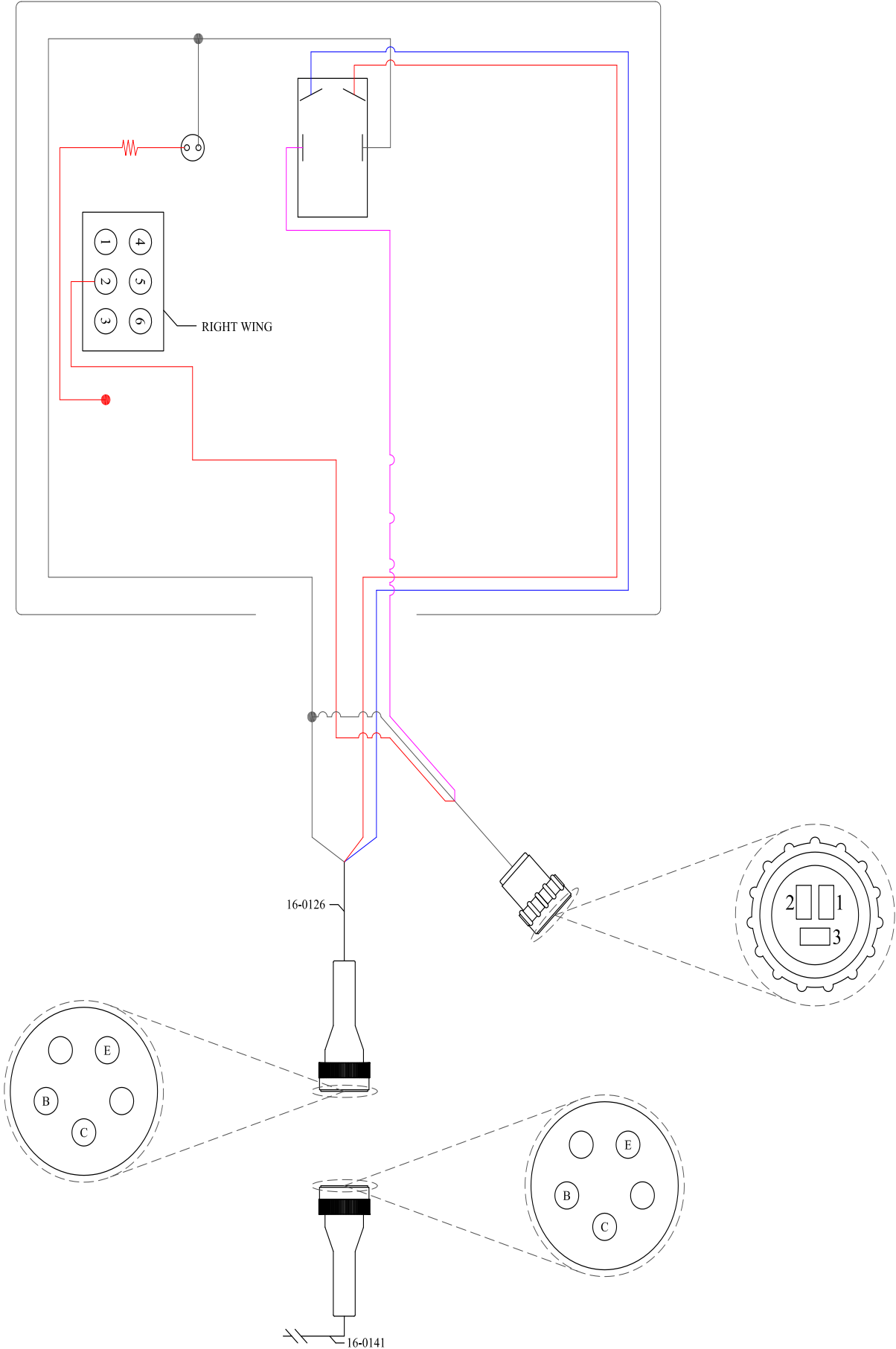

ELECTRICAL ASSEMBLIES - 10' HYDRAULIC FLEXWING, SCHEMATIC

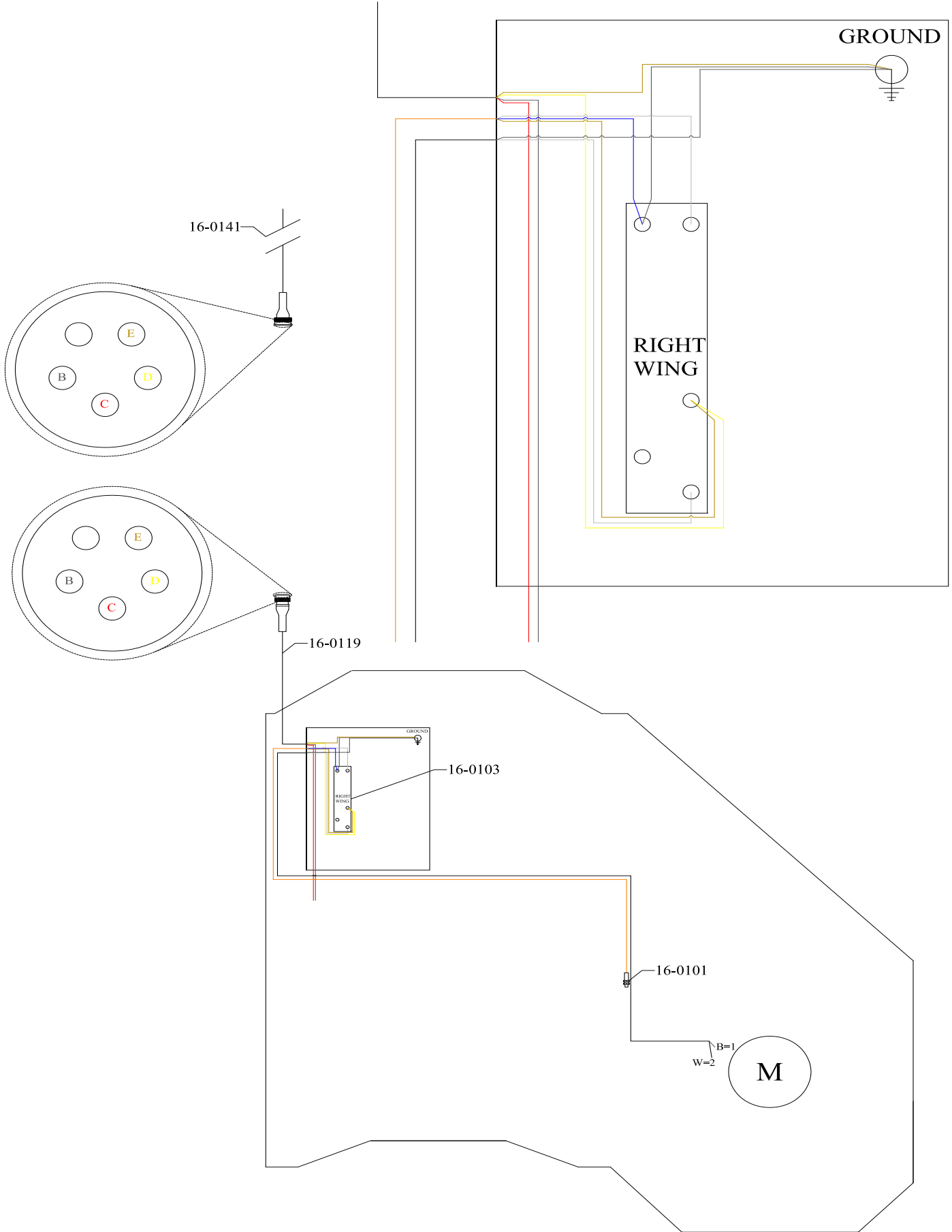

LIMIT SWITCH - DRAFT BEAM HEIGHT LIMITER

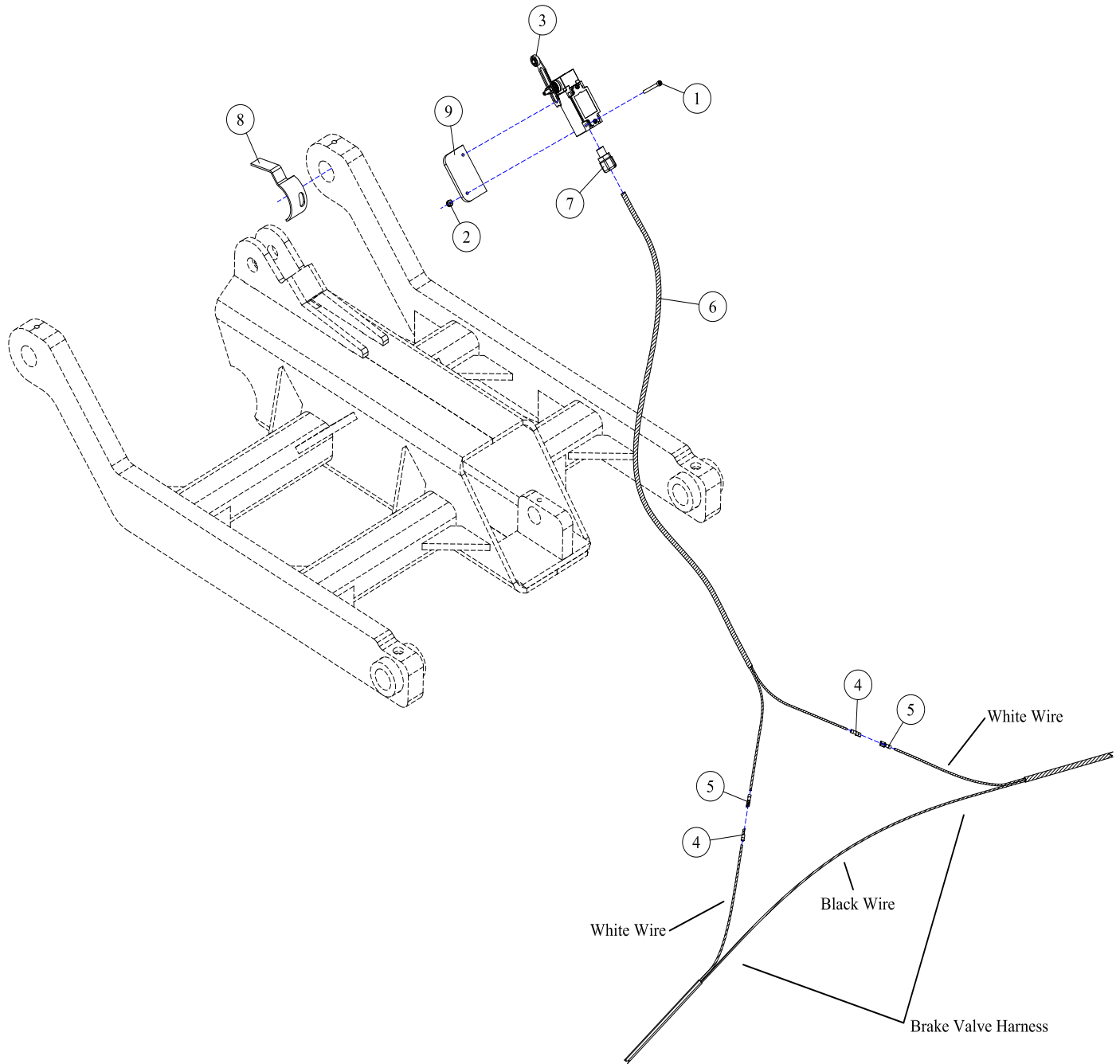

REF#	PARTS DESCRIPTION	REQ	PART #
1	#10 - 24 X 2 SHCS	2	11-0786
2	#10 - 24 NYLOCK NUT	2	11-1051
3	LIMIT SWITCH	1	16-0016
4	14-16GA MALE PUSH-ON CONNECTOR	2	16-0040
5	14-16GA FEMALE PUSH-ON CONNECTOR	2	16-0041
6	14/2 PRIMARY WIRE	Avail/ft	16-0042
7	3/8 CONDUIT STRAIN RELIEF	1	16-0043
8	<u>CAM TILT BRACKET</u>		
	LEFT	1	24-0039
	RIGHT	1	24-0040
9	LIMIT SWITCH PLATE	1	31-0023

DECK ASSEMBLIES



29-0049 - DRIVE LINE ASSEMBLY

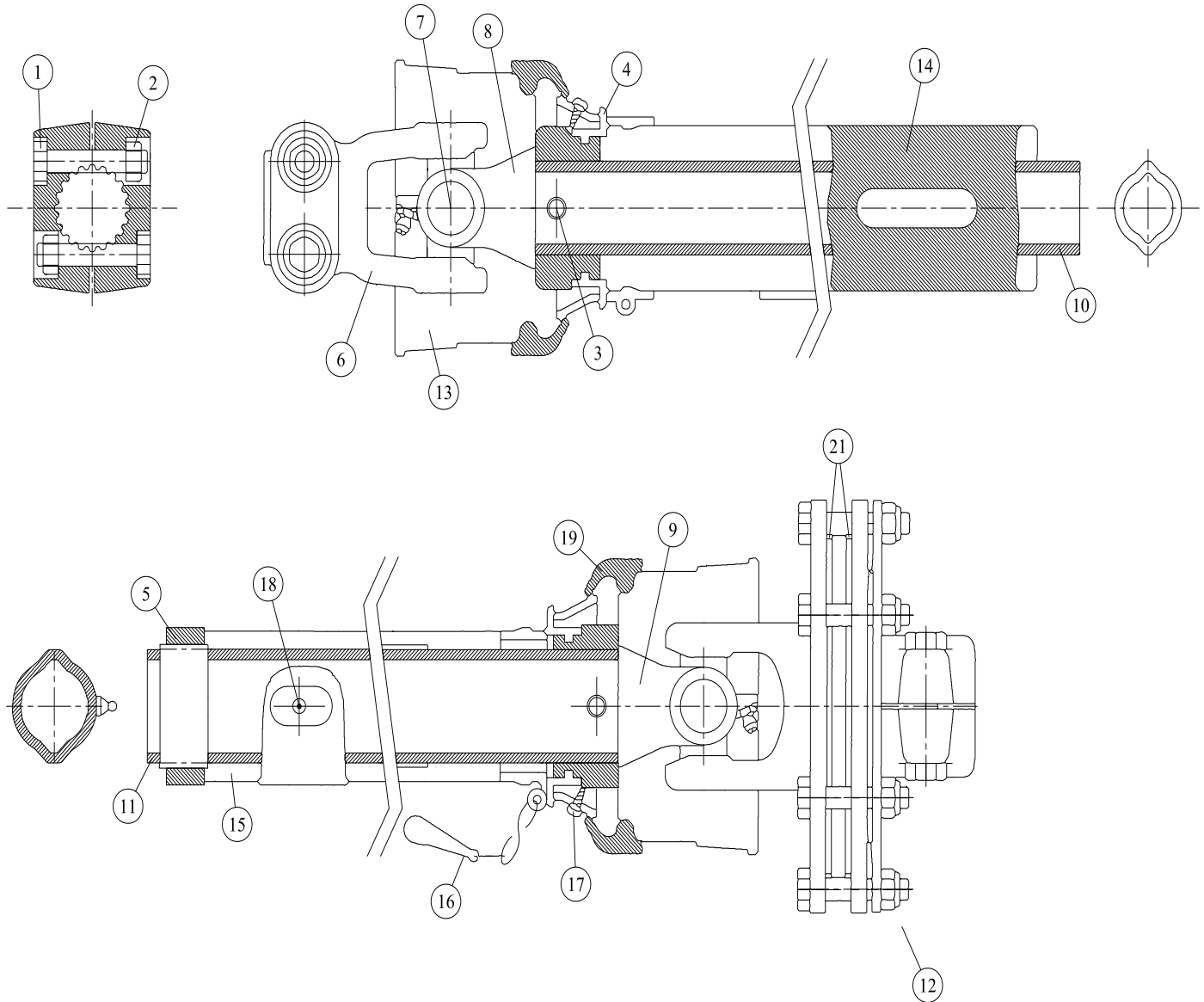

* Items # 13-17 & 19 are for reference only and not for individual sale.
 Items 4, 13-17 & 19 are included with item # 20 inner & outer shield complete.

REF#	PARTS DESCRIPTION	REQ	PART #
1	BOLT	2	11-0848
2	NUT	2	11-1045
3	SPRING PIN	2	29-0020
4*	BEARING RING	2	29-0026
5	SUPPORT BEARING	1	29-0027
6	YOKE	1	29-0059
7	CROSS AND BEARING KIT	2	29-0060
8	INBOARD YOKE (FRONT)	1	29-0061
9	INBOARD YOKE (REAR)	1	29-0062
10	INNER PROFILE	1	29-0063
11	PROFILE AND SLEEVE	1	29-0064

REF#	PARTS DESCRIPTION	REQ	PART #
12	FRICITION CLUTCH COMPLETE	1	29-0065
13*	GUARD CONE	2	
14*	GUARD TUBE (OUTER)	1	
15*	GUARD TUBE (INNER)	1	
16*	RESTRAINT CHAIN	1	
17*	SCREW	2	
18	ZERK	1	29-0073
19*	REINFORCING COLLAR	2	
20*	INNER & OUTER SHIELD COMPLETE	1	29-0132
21	FRICITION DISC	2	29-0134

29-0051 - DRIVE LINE ASSEMBLY

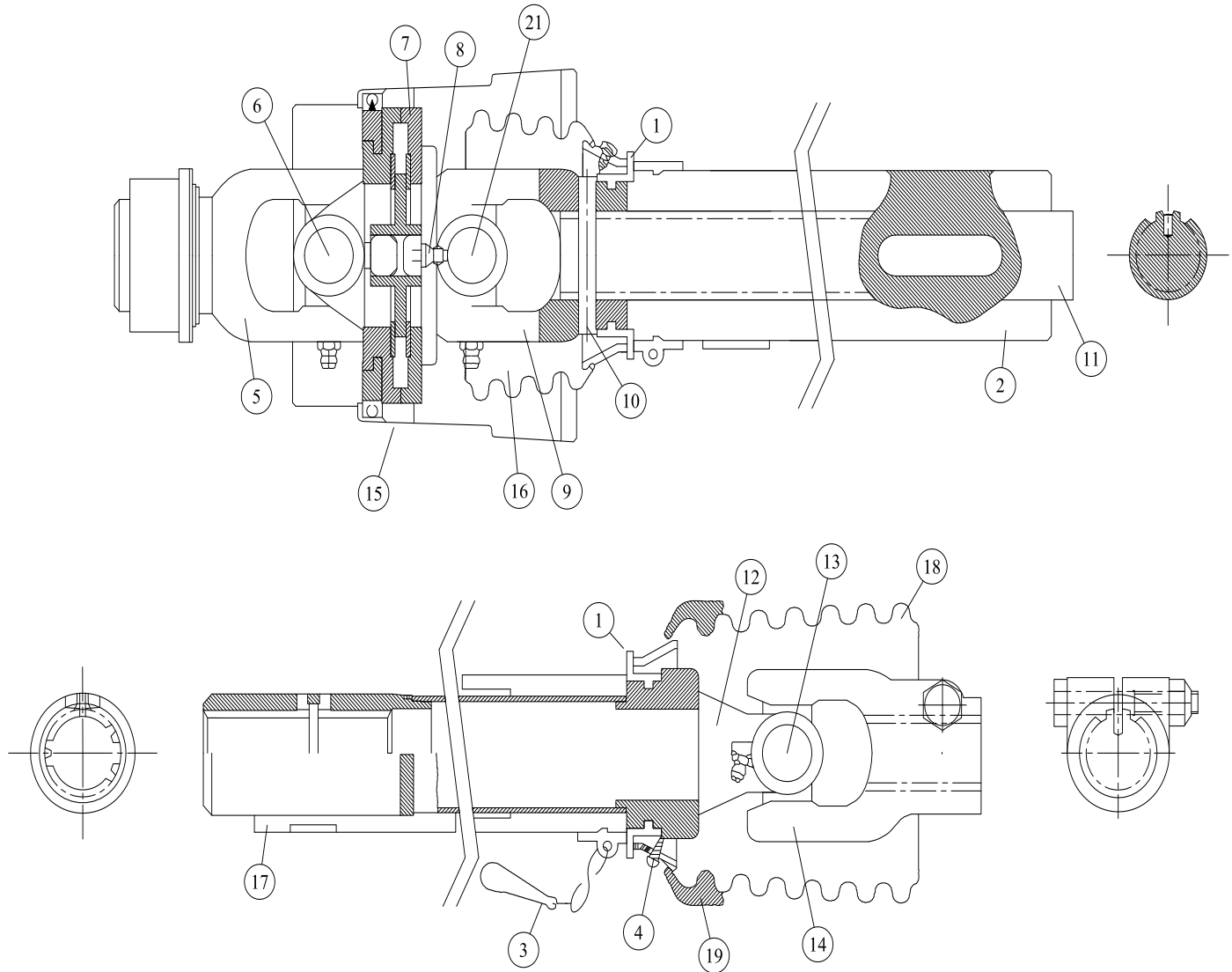

* Items # 2-4 & 16-19 are for reference only and not for individual sale.
 Items 1, 2-4 & 16-19 are included with item # 20 inner & outer shield complete.

REF#	PARTS DESCRIPTION	REQ	PART #
1*	BEARING RING	2	29-0026
2*	GUARD TUBE (OUTER)	1	
3*	RESTRAINT CHAIN	1	
4*	SCREW	2	
5	YOKE	1	29-0080
6	CROSS AND BEARING KIT	1	29-0081
7	DOUBLE YOKE	1	29-0082
8	ZERK	1	29-0083
9	INBOARD YOKE	1	29-0084
10	SPRING PIN	1	29-0085
11	INNER PROFILE	1	29-0086

REF#	PARTS DESCRIPTION	REQ	PART #
12	INBOARD YOKE, TUBE, AND SLEEVE	1	29-0087
13	CROSS AND BEARING KIT	1	29-0089
14	YOKE	1	29-0090
15	CV GUARD AND BEARING ASSEMBLY	1	29-0133
16*	GUARD CONE	1	
17*	GUARD TUBE (INNER)	1	
18*	GUARD CONE	1	
19*	REINFORCING COLLAR	1	
20*	INNER & OUTER SHIELD COMPLETE	1	29-0131
21	CROSS AND BEARING KIT	1	29-0140

19-0077 - GEAR BOX ASSEMBLY, SPLITTER

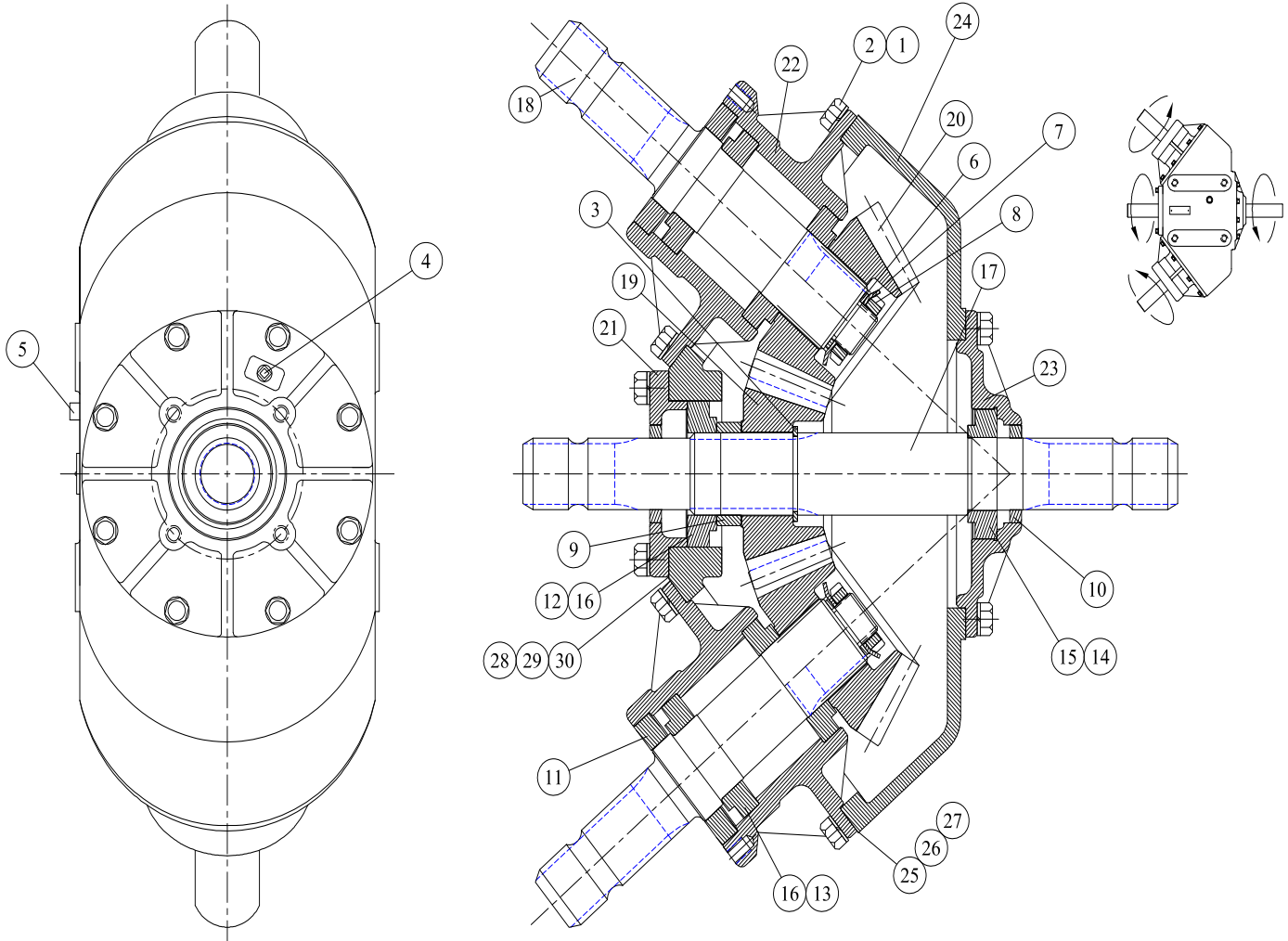

REF#	PARTS DESCRIPTION	REQ	PART #
1	3/8 LOCK WASHER	28	11-0005
2	3/8 X 1-1/4 NC HEX CAPSCREW	28	11-0533
3	RETAINING RING	1	19-0128
4	PLUG, OIL LEVEL	1	19-0129
5	PIPE PLUG, 1/2" SQUARE HEAD	1	19-0150
6	FLAT WASHER	2	19-0131
7	LOCK WASHER	2	19-0132
8	LOCK NUT	2	19-0133
9	SPACER	1	19-0134
10	SEAL	2	19-0135
11	SEAL	2	19-0136
12	BEARING CUP	1	19-0137
13	BEARING CUP	4	19-0138
14	BEARING CUP	1	19-0139
15	BEARING CONE	1	19-0140

REF#	PARTS DESCRIPTION	REQ	PART #
16	BEARING CONE	5	19-0141
17	SHAFT, INPUT 1.75" - 20 SPLINE (LONG)	1	19-0142
18	SHAFT, OUTPUT 1.75" - 20 SPLINE (SHORT)	2	19-0143
19	PINION	1	19-0144
20	GEAR	2	19-0145
21	CAP, OUTPUT	1	19-0146
22	CAP, CANTILEVERED OUTPUT	2	19-0147
23	CAP, INPUT	1	19-0148
24	HOUSING	1	19-0149
25	GASKET, 0.10	VAR	CALL
26	GASKET, 0.15	VAR	CALL
27	GASKET, 0.30	VAR	CALL
28	GASKET, 0.10	VAR	CALL
29	GASKET, 0.15	VAR	CALL
30	GASKET, 0.30	VAR	CALL

19-0078 - GEAR BOX ASSEMBLY

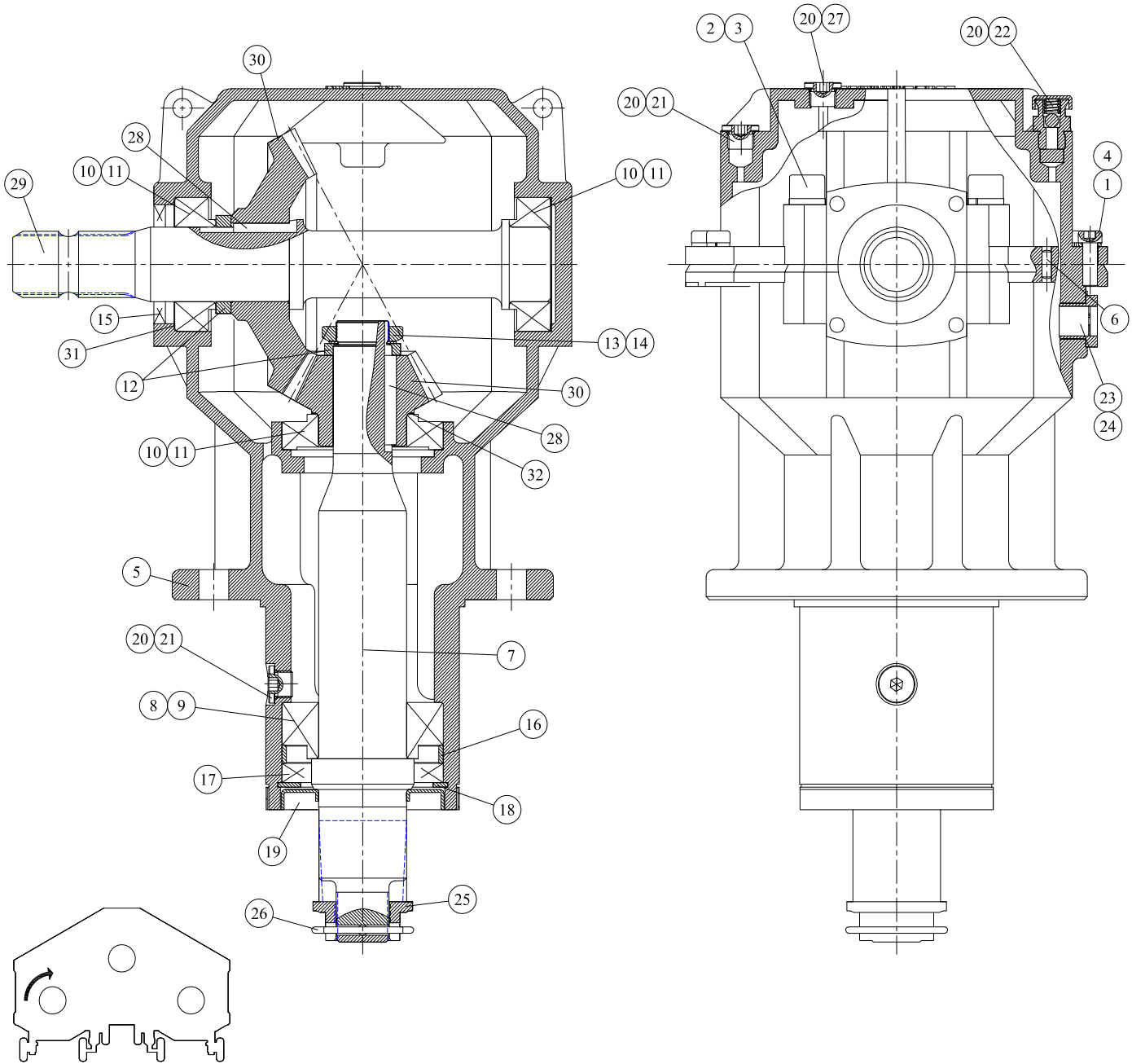

REF#	PARTS DESCRIPTION	REQ	PART #
1	LOCK WASHER, M10	6	11-0069
2	LOCK WASHER, M16	4	11-0071
3	SOCKET-HEAD CAPSCREW, M16 - 2.0 X 70	4	11-0854
4	SOCKET-HEAD CAPSCREW, M10 - 1.5 X 30	6	11-0855
5	HOUSING	1	19-0086
6	DOWEL PIN, Ø 6.35 X 19	2	19-0087
7	SHAFT, OUTPUT SPLINE 18T	1	19-0088
8	BEARING CONE	1	19-0089
9	BEARING CUP	1	19-0090
10	BEARING CONE	3	19-0091
11	BEARING CUP	3	19-0092
12	SPACER SHAFT	2	19-0095
13	LOCKING WASHER	1	19-0096
14	LOCKING NUT	1	19-0097
15	SEAL, INPUT	1	19-0098
16	SPACER, OUTPUT SEAL	1	19-0099

REF#	PARTS DESCRIPTION	REQ	PART #
17	SEAL, OUTPUT	1	19-0100
18	RETAINING RING	1	19-0101
19	SHIELD, OUTPUT	1	19-0102
20	O-RING, Ø 2.62 X Ø 12.37	4	19-0103
21	FLANGE PLUG, M18 X 1.5	2	19-0104
22	PLUG, PRESSURE RELIEF, M18 X 1.5	1	19-0105
23	O-RING	1	19-0106
24	OIL SIGHT GLASS, M27 X 1.5	1	19-0107
25	HEX NUT, SLOTTED, M36 X 3	1	19-0108
26	COTTER PIN, 6.3 X 60	1	19-0109
27	FLANGE PLUG WITH DIP STICK	1	19-0110
28	KEY, 12 X 8 X 38	2	19-0111
29	SHAFT, INPUT 1.75" - 20 SPLINE	1	19-0113
30	SPIRAL GEAR/ PINION ASSEMBLY	1	19-0115
31	SPACER, INPUT (VAR. THICKNESS)	VAR	CALL
32	SHIM, OUTPUT (VAR. THICKNESS)	VAR	CALL

19-0081 - GEAR BOX ASSEMBLY

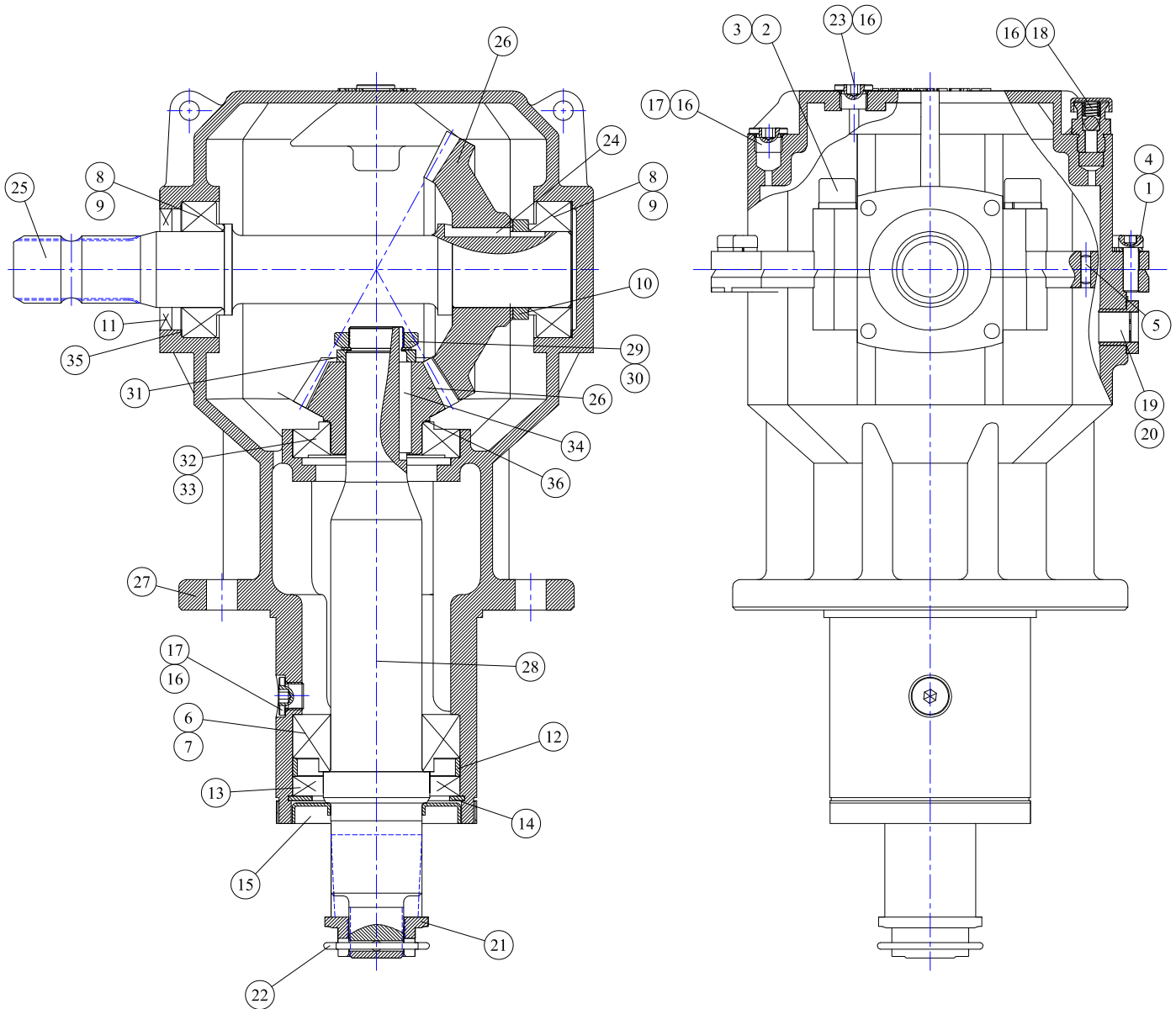

REF#	PARTS DESCRIPTION	REQ	PART #
1	LOCK WASHER, M10	6	11-0069
2	LOCK WASHER, M16	4	11-0071
3	SOCKET-HEAD CAPSCREW, M16 - 2.0 X 70	4	11-0854
4	SOCKET-HEAD CAPSCREW, M10 - 1.5 X 30	6	11-0855
5	DOWEL PIN, Ø 6.35 X 19	2	19-0087
6	BEARING CONE	1	19-0089
7	BEARING CUP	1	19-0090
8	BEARING CONE	2	19-0091
9	BEARING CUP	2	19-0092
10	SPACER SHAFT	1	19-0095
11	SEAL, INPUT	1	19-0098
12	SPACER, OUTPUT SEAL	1	19-0099
13	SEAL, OUTPUT	1	19-0100
14	RETAINING RING	1	19-0101
15	SHIELD, OUTPUT	1	19-0102
16	O-RING, Ø 2.62 X Ø 12.37	4	19-0103
17	FLANGE PLUG, M18 X 1.5	2	19-0104
18	PLUG, PRESSURE RELIEF, M18 X 1.5	1	19-0105

REF#	PARTS DESCRIPTION	REQ	PART #
19	O-RING	1	19-0106
20	OIL SIGHT GLASS, M27 X 1.5	1	19-0107
21	HEX NUT, SLOTTED, M36 X 3	1	19-0108
22	COTTER PIN, 6.3 X 60	1	19-0109
23	FLANGE PLUG WITH DIP STICK	1	19-0110
24	KEY, 12 X 8 X 38	1	19-0111
25	SHAFT, INPUT 1.75" - 20 SPLINE	1	19-0112
26	SPIRAL GEAR/ PINION ASSEMBLY	1	19-0118
27	HOUSING	1	19-0119
28	SHAFT, OUTPUT SPLINE 18T	1	19-0120
29	LOCKING WASHER	1	19-0121
30	LOCKING NUT	1	19-0122
31	SPACER SHAFT	1	19-0123
32	BEARING CONE	1	19-0124
33	BEARING CUP	1	19-0125
34	KEY, 10 X 8 X 60	1	19-0126
35	SPACER, INPUT (VAR. THICKNESS)	VAR	CALL
36	SHIM, OUTPUT (VAR. THICKNESS)	VAR	CALL

30-0518 - MOTOR ASSEMBLY

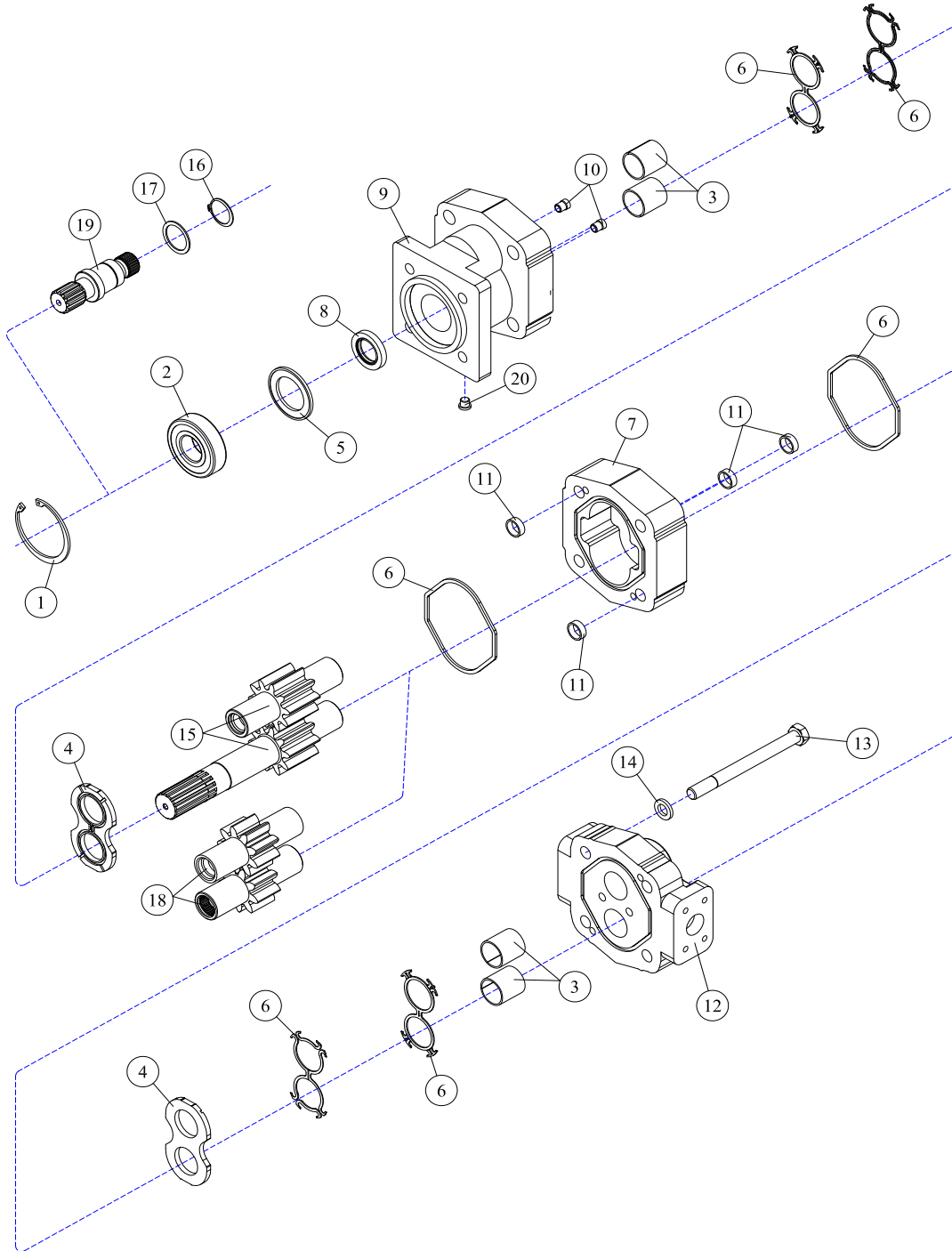

REF#	PARTS DESCRIPTION	REQ	PART #
1	SNAP RING	1	30-1009
2	OUTBOARD BEARING	1	30-1010
3	BUSHING	4	30-1011
4	THRUST PLATE	2	30-1012
5	SEAL RETAINER	1	30-1017
6	M365 SEAL KIT	Avail	30-1021
7	2-1/2" M365 GEAR HOUSING	1	30-1137
8	SHAFT SEAL		
	150 PSI (included in M365 seal kit)	1	30-1210
	500 PSI	1	30-1156
9	SHAFT END COVER	1	30-1086
10	CHECK ASSEMBLY	2	30-1087
11	ALIGNMENT BUSHING	4	30-1090

REF#	PARTS DESCRIPTION	REQ	PART #
12	PORT END COVER	1	30-1091
13	STUD	4	30-1334
14	WASHER	4	30-1093
	GEAR SET OPTION A:		
15	2-1/2" GEAR SET	1	30-1170
	GEAR SET OPTION B:		
16	RETAINING RING	1	30-1019
17	WASHER	1	30-1020
18	2-1/2" GEAR SET	1	30-1136
19	CONTINENTAL SHAFT, SPLINED	1	30-1144
20	PLUG	1	30-1096
*	SEAL APPLICATOR TOOL (not shown)	Avail	30-1048

30-0017 - PUMP ASSEMBLY

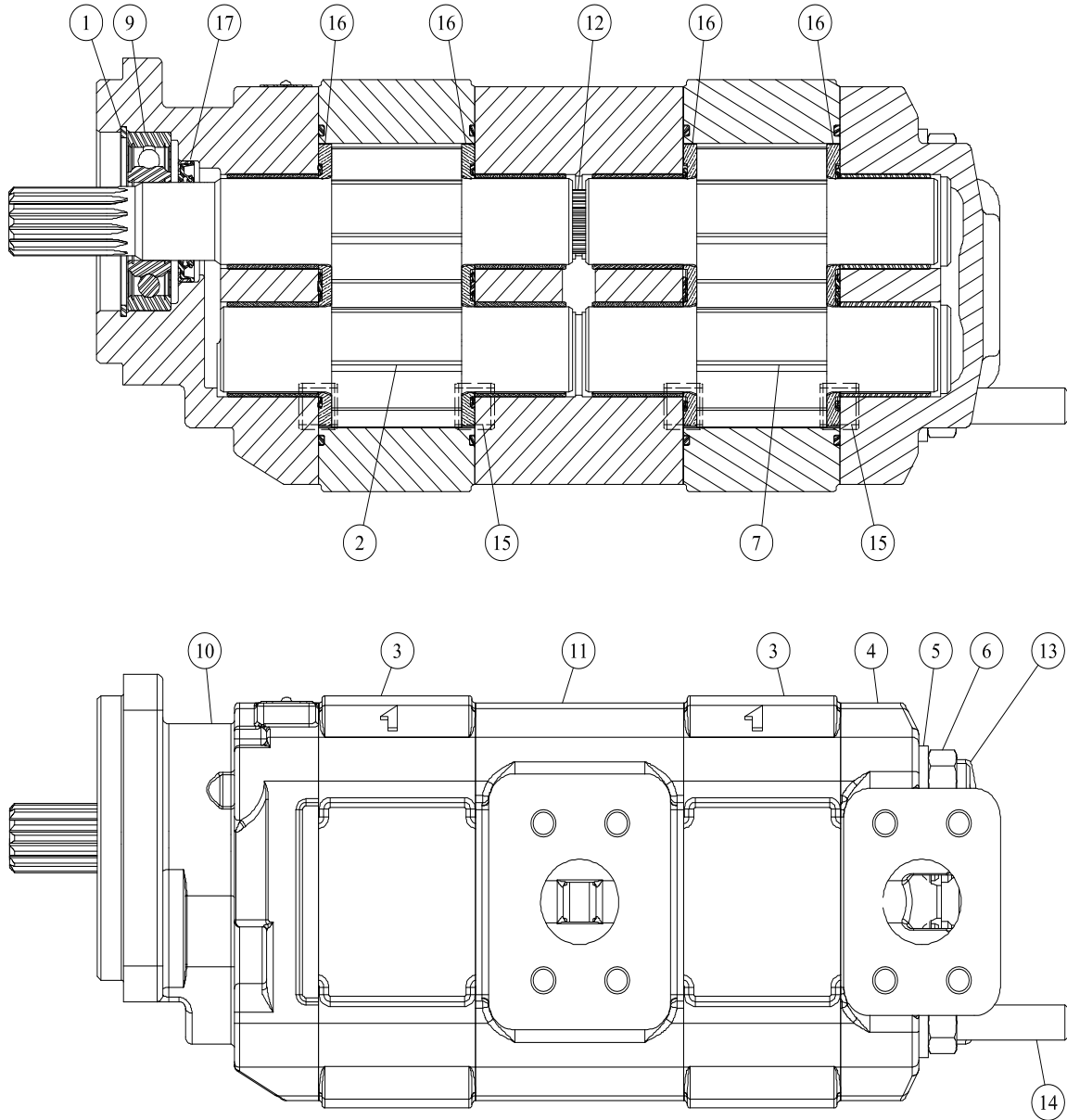

*Complete seal kit can be purchased using part 30-1172.

**Item # 17 shaft seal is included with complete seal kit.

REF#	PARTS DESCRIPTION	REQ	PART #
1	SNAP RING	1	30-1009
2	GEAR SET & SHAFT	1	30-1079
3	GEAR HOUSING	2	30-1082
4	PORT END COVER	1	30-1083
5	WASHER	4	30-1127
6	HEX NUT	4	30-1128
7	GEAR SET	1	30-1136
8	SEAL KIT	1	30-1172
9	BEARING	1	30-1173

REF#	PARTS DESCRIPTION	REQ	PART #
10	SHAFT END COVER	1	30-1174
11	BEARING CARRIER	1	30-1175
12	CONNECTING SHAFT	1	30-1176
13	STUD	2	30-1177
14	STUD	2	30-1178
15	DOWEL PIN	16	30-1179
16	THRUST PLATE	4	30-1180
17	SHAFT SEAL	1	30-1181

17-0014 - FILTER ASSEMBLY

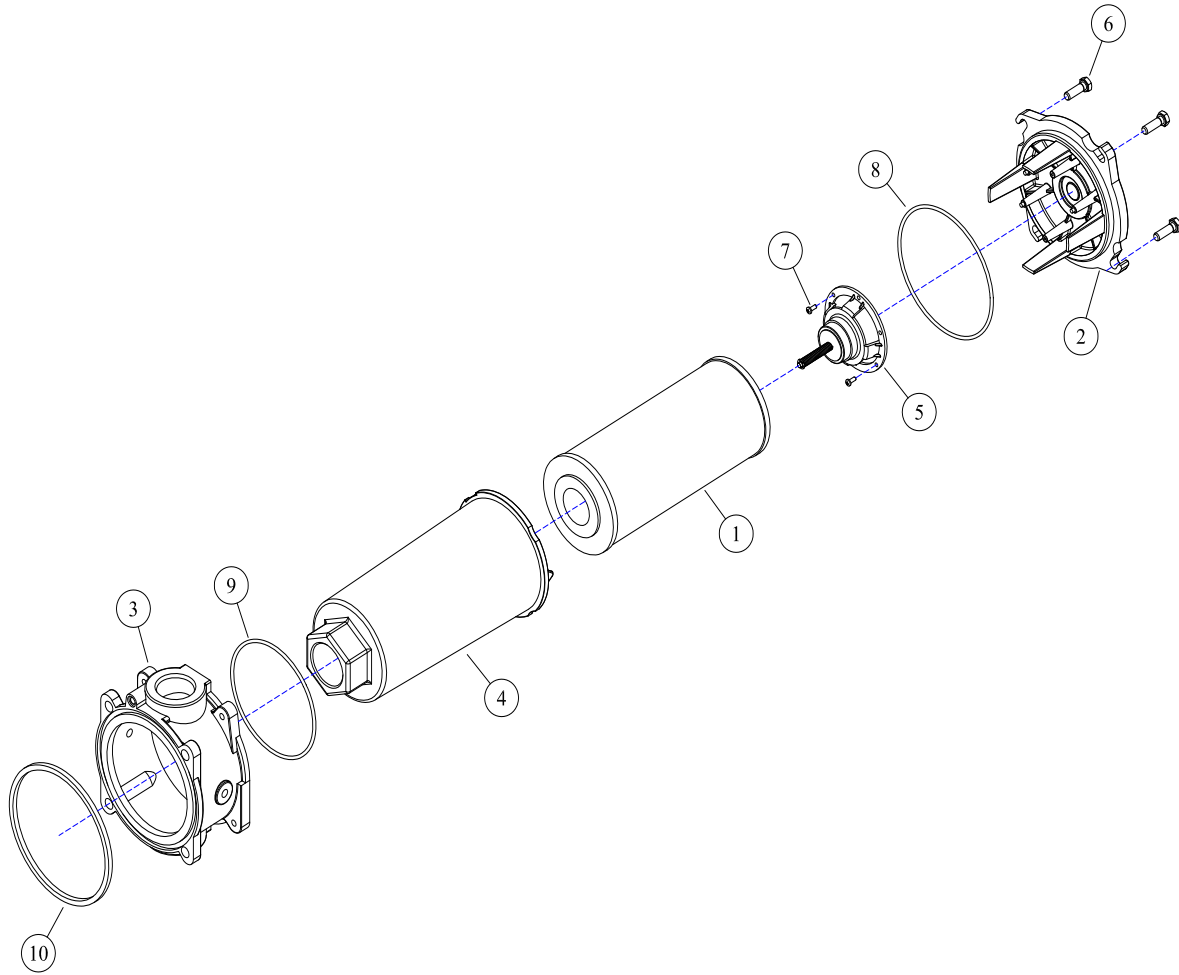

REF#	PARTS DESCRIPTION	REQ	PART #
1	FILTER ELEMENT	1	17-0001
2	COVER	1	17-0016
3	PORT CASTING	1	17-0017
4	ELEMENT HOUSING	1	17-0018
5	BY-PASS ASSEMBLY	1	17-0019
6	SCREW (COVER)	4	17-0020
7	SCREW (BY-PASS ASSEMBLY)	2	17-0021
8	O-RING, COVER/PORT CASTING	1	33-0005
9	O-RING, ELEMENT/PORT CASTING	1	33-0053
10	TETRA SEAL	1	33-0018

35-0088 - DIRECT DRIVE SPINDLE

Grease with #2 lithium based grease every 500hrs.
Use 10 pumps (.44oz) into each of the two grease zerk.

Warning: Do not overgrease
Overgreasing will cause damage or premature failure of the bearings, housing & seals.

REF#	PARTS DESCRIPTION	REQ	PART #
1	BEARING	2	10-0055
2	LOCKING WASHER	1	11-0048
3	3/8 X 2-3/4 NC SKT HEAD CAPSCREW	8	11-0703
4	1/4 X 1/2 NC CAPSCREW	4	11-0741
5	2-1/2 SPANNER NUT	1	11-1037
6	LARGE SNAP RING	1	11-2021
7	SMALL SNAP RING	1	11-2022
8	PIPE PLUG	1	21-1136
9	1/8 X 90 GREASE ZERK	2	23-0005
10	UPPER SEAL	1	33-0035
11	LOWER SEAL	1	33-0057
12	SPINDLE HOUSING	1	35-0021
13	SEAL/MOTOR MOUNT	1	35-0022
14	ALIGNMENT PIN	2	35-0032
15	SPACER	1	35-0050
16	BOTTOM SEAL PLATE	1	35-0063
17	SPACER	1	35-0064
18	BOTTOM PLATE	1	35-0065
19	GREASE CATCH	1	35-0066
20	SPINDLE SHAFT COMPLETE	1	35-0090
*21	SPLINED INSERT KIT	1	35-0091
22	BREATHER	2	80-1016
23	3/8 LOCK WASHER GR 5	8	11-0005

* The splined insert kit includes the insert removal tool 11-0913.

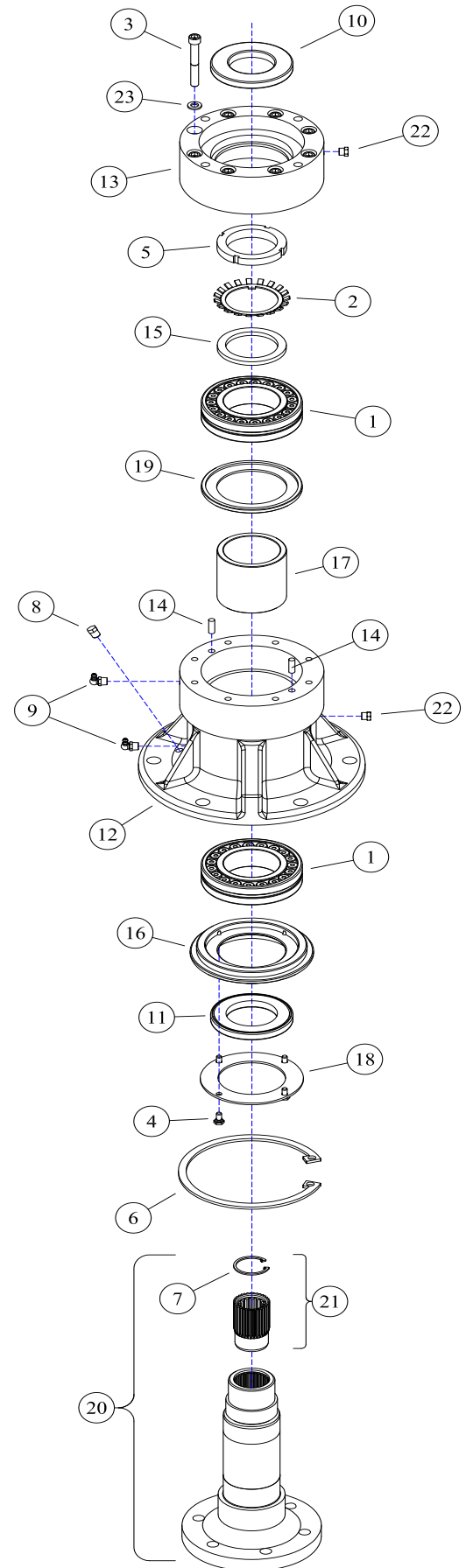

LIFT ASSEMBLIES

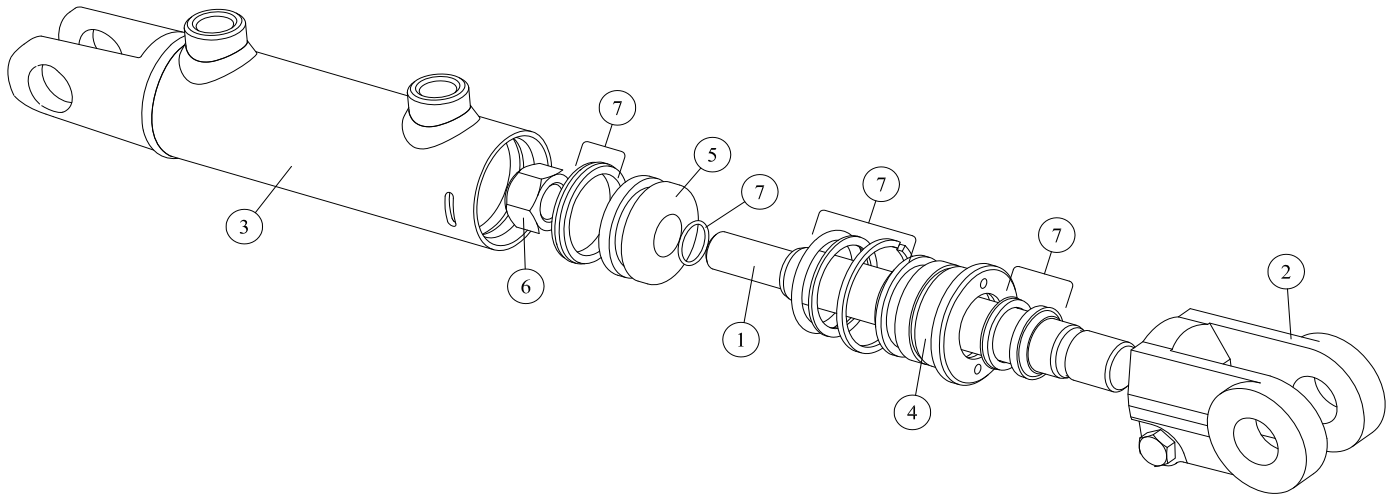

14-0001 - 3X10 WELDED CYLINDER

REF#	PARTS DESCRIPTION	REQ	PART #
1	PISTON ROD	1	14-1130
2	CLEVIS ASSEMBLY	1	14-1160
3	BUTT & TUBE ASSEMBLY	1	14-1140
4	GLAND	1	14-1155
5	PISTON	1	14-1150
6	LOCKNUT	1	14-1120
7	SEAL KIT	1	33-0038

14-0040 - 2.8X8 REPHASING CYLINDER, 1.125" ROD

UNDER

CONSTRUCTION

(PAGE INTENTIONALLY BLANK)



**100% SATISFACTION
GUARANTEE**
★ GET IT, LOVE IT, *or* LEAVE IT! ★

**72-HOUR PARTS
SHIPPING GUARANTEE**