



**SKID-STEER / COMPACT TRACK LOADER
ROTARY MOWER**

OPERATOR'S MANUAL



**350 EAST 60TH ST. N. • SIOUX FALLS, SD 57104
800.658.5561 • 605.977.3300
WWW.DIAMONDMOWERS.COM**

**PARTS 888.960.0361
WARRANTY + SERVICE 888.960.0364**



PRODUCT INFORMATION

Record the model and serial number of your unit here. When calling for warranty, service, or parts, you may be asked to provide this information, in order to ensure fast, accurate service.

MODEL: Rotary Mower

SIZE: 60"(1524mm) 72"(1829mm) 84"(2134mm)
(circle one)

SERIAL NUMBER: _____

Any failure to read, understand and follow the instructions found in this operator's manual could lead to serious injury. Operators who choose to operate this equipment without following instructions, or who choose to operate this equipment in a manner inconsistent with the recommendations set forth in this manual, do so at their own risk and assume the risk of injury. Diamond Mowers will not be liable for an owner or operator's loss, damage, or injury due to the misuse of the equipment, failure to understand the inherent risks, or inability to properly operate the equipment.

© Diamond Mowers, LLC
All rights reserved.

WELCOME!

Thank you for choosing Diamond Mowers, and welcome to your Skid-Steer / Compact Track Loader Rotary Mower. Before you begin operating, we encourage you to look through this manual to review the proper maintenance and operating techniques that will keep you, and your equipment, safe – while ensuring you the most productive Rotary Mower in the market.

We have nothing but respect and admiration for you. Our job at Diamond is to provide you with the toughest, most reliable and safest equipment that will allow you to do your job better. That also means being there when you need us.

CONTACT US:

Parts: 888.960.0361 | parts@diamondmowers.com

Warranty / Service: 888.960.0364 | warranty@diamondmowers.com

Main Office: 800.658.5561 | 605.977.3300

Website: www.diamondmowers.com | **Email:** info@diamondmowers.com

Your time is important to us.

We guarantee that Genuine Diamond Parts will ship within 72-hours of the order being placed or the parts and shipping are free.

Your satisfaction is guaranteed.

If you are not completely satisfied with your new Diamond in the first 30-days, we will buy it back. No questions asked.

Thanks again for choosing Diamond.

If at any time your needs are not being met by our team, please feel free to call me direct.



Tim Kubista
VP Sales & Marketing
651.955.6665

OWNER REGISTRATION

In your welcome packet you should have received a warranty registration form. Complete and return this form to our main office.

If you'd rather complete this info online, go to:
<http://info.diamondmowers.com/register-my-product>

Returning your registration information to Diamond will help us process any warranty claims quickly and efficiently - so you can get back to work, fast.

TRANSFERRED OWNERSHIP

If you have acquired this Rotary Mower from a previous owner, we encourage you to register your equipment online. By registering your Diamond Mowers unit, you'll stay informed on product advancements, offers and service alerts.

Register by going to: <http://info.diamondmowers.com/register-my-product>

We honor our equipment's warranty from the date it was put into service, no matter who's in charge of running it.

For any questions, contact our Warranty / Service team at:
888.960.0364 or 605.977.3300
warranty@diamondmowers.com



TABLE OF CONTENTS

INTENDED USE.....	6
TAKE A LOOK AROUND.....	7
GETTING STARTED.....	8
OPERATING YOUR ROTARY MOWER.....	10
MAINTENANCE INTERVALS.....	18
TROUBLESHOOTING.....	24
PARTS BOOK.....	27
INDEX.....	47

INTENDED USE

This attachment is designed to be used for mowing and brush management applications.

This includes:

- Cutting grass.
- Mulching brush.
- Cutting 4" (102mm) material continuously and 10" (254mm) material intermittently.

This attachment should only be used in an area free of obstructions and bystanders. Any use on non-vegetative material, or in an area that is not clear of persons and property, is strictly prohibited. Any use outside of the aforementioned application is considered contrary to its intended use. Any damage that may occur as a result of misuse will void warranty as stated in Diamond Mowers' warranty policy.

NOTICE

Do not operate this unit without first reading the safety precautions and operating instructions in this manual.

TAKE A LOOK AROUND

Let's get started by doing a quick walk around of the Rotary Mower.

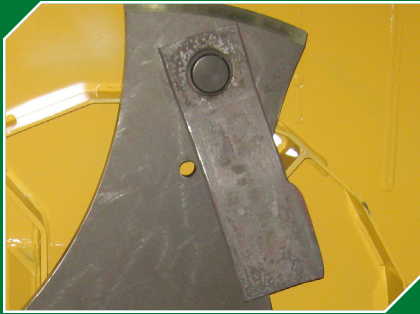

BLADES

Three, hardened steel knives $\frac{5}{8}$ " (16mm) thick. The blades are built to swing, allowing them to break away when in contact with rocks.



PUSH BAR

Guides material away from the loader.

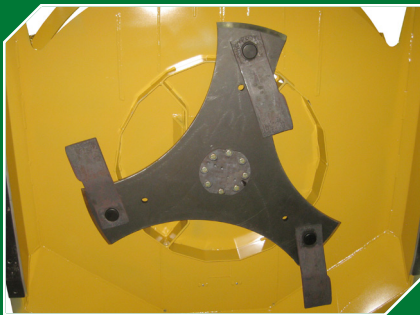

TRI-HEX DISC

It is important to build momentum in the cutting disc and allow for recovery time. This disc acts like a flywheel and stores energy. It will take some time for the disc to come up to full speed. If the disc begins to slow down in heavy brush or while cutting large trees, slow your movements to allow the disc to return to full speed.



HOSES

Shipped with $\frac{1}{2}$ " QD couplers and a case drain line with both male and female ends. High flow motors are equipped with a case drain line while standard flow motors are not. If your mower is equipped with a case drain line, ensure that it is properly connected and unrestricted to tank.

GETTING STARTED



MACHINE FLOW

Diamond's Skid-Steer / Compact Track Loader Rotary Mowers can be used on either a low flow or high flow machine capable of 16-46 GPM (61-175 LPM). Make certain the Rotary Mower you purchased is sized right for your Skid-Steer / Compact Track Loader .

DECK SIZE	GPM	LPM	CASE DRAIN
60" (1524mm) Deck	16-28	61-106	No
	29-46	110-174	Yes
72" (1829mm) Deck	17-28	65-106	No
	29-41	110-155	Yes
84" (2134mm) Deck	32-41	122-152	Yes



SHATTER RESISTANT ENCLOSURE

A shatter resistant enclosure is **REQUIRED!** This product must not be used without a shatter resistant cab enclosure. Debris can fly back at the cab and cause injury.



QUICK ATTACH

The Rotary Mower will mount onto the front of the Skid-Steer / Compact Track Loader quick attach plate in place of a bucket or other implements.

CONTINUED ON NEXT PAGE



QD COUPLERS

The case drain line must be properly connected or you will damage your hydraulic motor. The case drain line will come equipped with both male and female QD couplers.

- Install the QD coupler(s) that matches the Skid-Steer / Compact Track Loader.
- Attachment is shipped with 1/2" flat face connectors, which are a common size for most Skid-Steer / Compact Track Loaders.
- Clean connections before attaching to prevent contamination.
- Make sure the hose length outside of the bracket is long enough for the head to make a full range of motion, but not so long that the hose can pinch.
 - An additional hose bracket location  is provided. If you need to move your hoses, unbolt the hoses and hose bracket from the current position and secure them to the alternate position.
- Start machine at low idle and verify that the disc is spinning in a clockwise direction as viewed from the operator's position.
 - If the pressure and return hoses are reversed, the disc will spin counter-clockwise resulting in damage.
 - If this reversal occurs, either inverse the flow from your machine, or switch the QD couplers on the pressure and return hoses.



OPERATING YOUR ROTARY MOWER

Before you operate, note that the primary responsibility for safety on this equipment falls to the operator. Only trained individuals who have read and understood this manual should operate this unit.

If any portion of this manual is not understood, contact Diamond Mowers' Service/Warranty at 888.960.0364 or 605.977.3300.

SAFETY TIPS

Be sure to read all warnings carefully. They are included for your safety, and for the safety of others working with you.

CAUTION

Indicates where *MINOR* injury *COULD* result if instructions are not followed.

WARNING

Indicates where *SERIOUS* injury or death *COULD* result if instructions are not followed.

DANGER

Indicates where *SERIOUS* injury or death *WILL* result if instructions are not followed.

NOTICE

Indicates a property damage hazard *ONLY*, no *PERSONAL* injury.

- Always wear proper safety glasses, goggles, or a face shield when operating.
- **DO NOT** operate this unit without a shatter resistant cab enclosure installed on your skid-steer / compact track loader; this unit will cause flying debris.
- Block off work area from bystanders, livestock, etc.
- Bystanders must keep a distance of 300'/100m from the unit when operating.

CONTINUED ON NEXT PAGE

- Knives are always sharp and can cause injury, even when not in motion.
- **DO NOT** use extremities to dislodge debris from the blades or disc.
- Operate only from the operator's station.
- Hydraulic fluid is hot and will heat any exposed steel, hoses, motor, or spindle in its proximity.
- Route hoses correctly to ensure a full range in motion.
- Make certain hoses are out of the way of tires, tracks or the ground.
- Be certain the disc has come to a complete stop before exiting the cab.



STOWED POSITION

When transporting Diamond's Rotary Mower between operations, make sure to protect it from collisions and accidental damages by placing it in the stowed position.

Failure to place the head in its stowed position could result in structural damage.

DANGER

Contact with the disc and knives while the disc is in motion will cause serious injury or death. The disc spins at a very high speed and can take several minutes to stop. Be sure all personnel are clear of the machine before engaging the mower.

CONTINUED ON NEXT PAGE

OPERATING TECHNIQUES

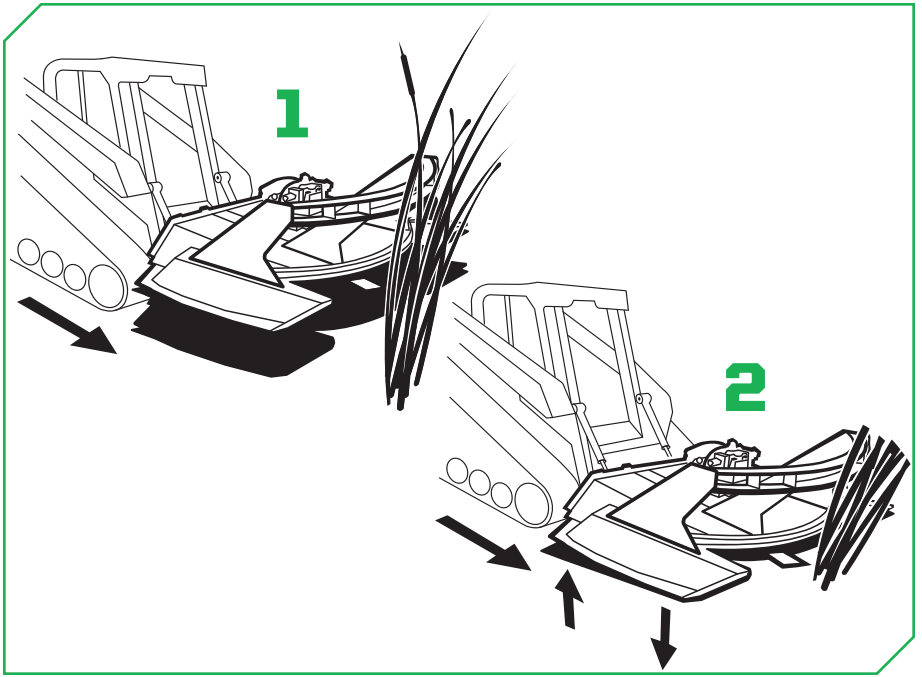

GRASS & BRUSH CUT

Use to cut grass or brush.

- 1** Lower the front of the deck slightly to ensure that there is ample room for exhausted material to be dispersed.
 - If you hear the blades, or engine slow down, lift up the head and/or slow your ground speed.

- 2** A second pass may be needed for heavy brush or grass.
 - Complete the initial pass at 12" (305mm) into the material.
 - Complete a second pass at ground level to thoroughly mulch the remaining material.

CONTINUED ON NEXT PAGE

OPERATING TECHNIQUES

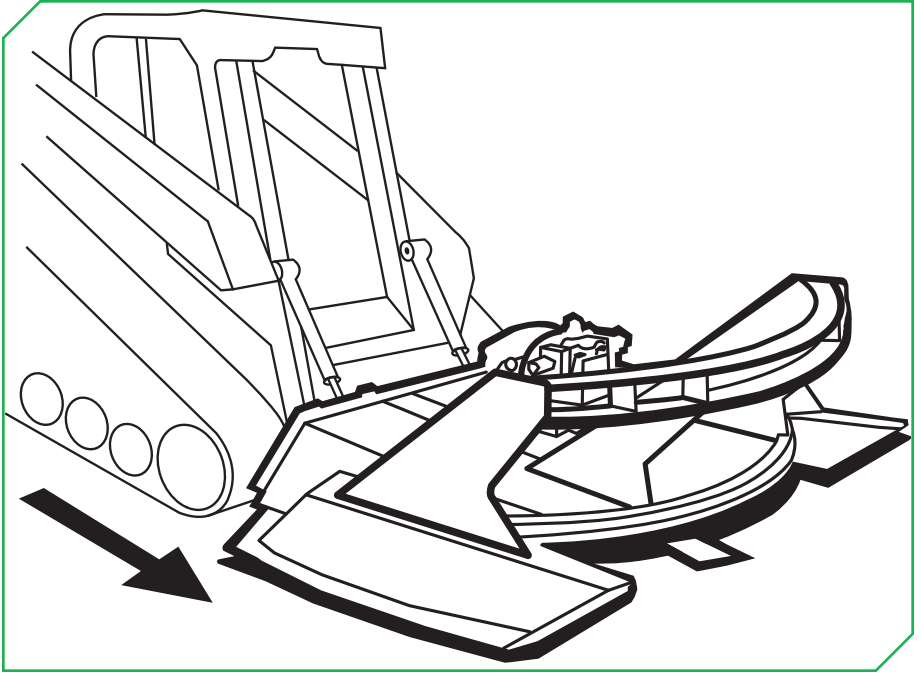

FINISHED MOW

Use for a finished look.

- Drive straight into the material keeping the deck low and level, or slightly pitched forward.
- Maintain speed of the disc and ground speed.

CONTINUED ON NEXT PAGE

OPERATING TECHNIQUES

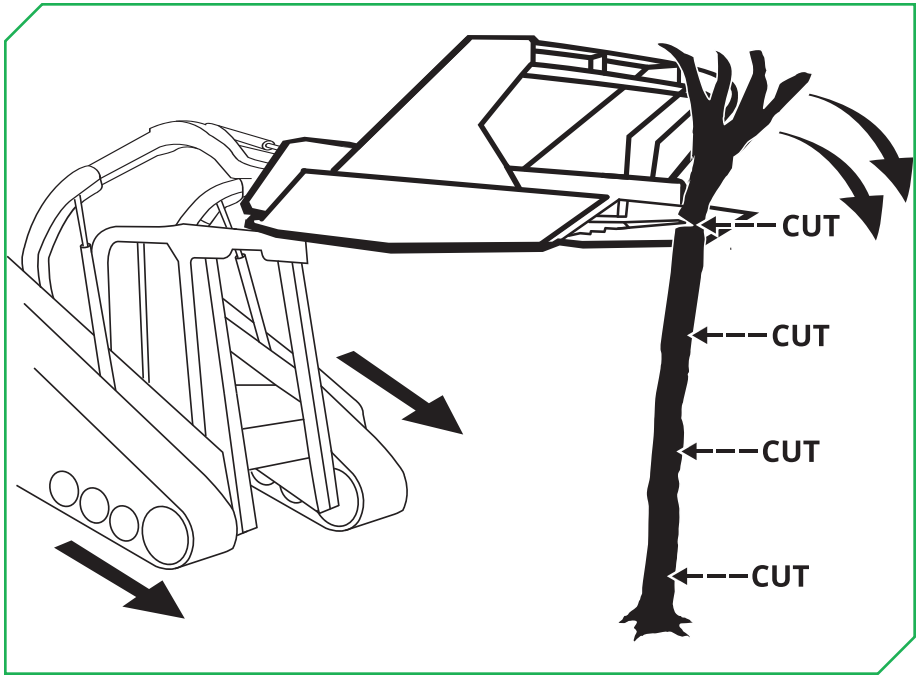

TREE CUT

Use to cut tree without mulching.

- On large trees, start working at the top and cut the tree in 12" (305mm) increments.
- With the Rotary Mower lifted slightly, drive straight into the material.
- Use the push bar to push the tree over while cutting.
- Use a smooth, quick action to cut the material completely.
 - **NOTE:** Never drop the mower straight down on trees. Severe damage will incur. **NO PANCAKING!**

CONTINUED ON NEXT PAGE

OPERATING TECHNIQUES

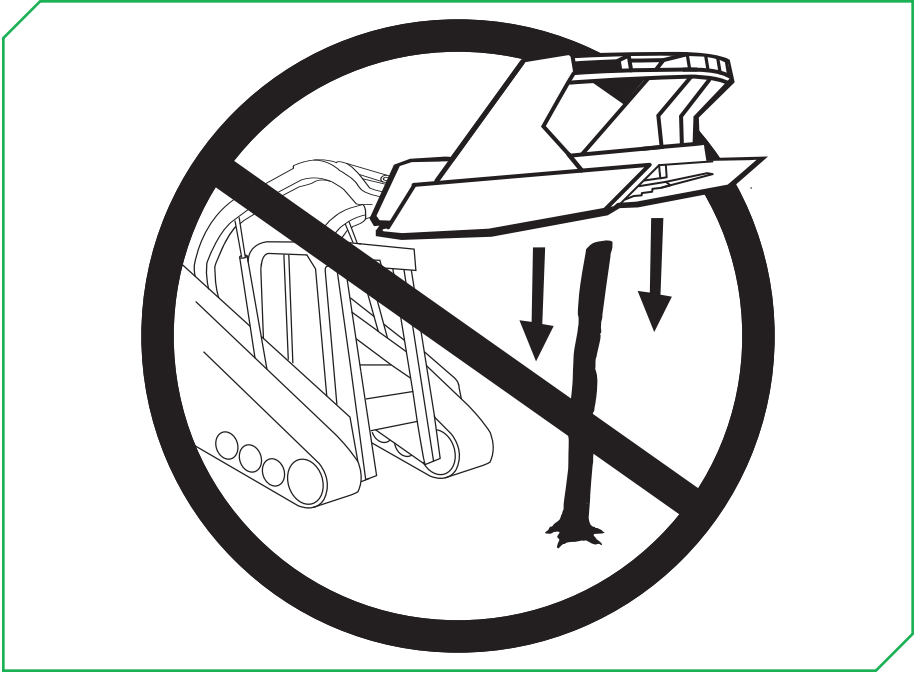

NO PANCAKING

DO NOT pancake.

- This machine is not built to drop on top of material for cutting or mulching. Damage will incur to the blades and spindle as a result of driving down (pancaking) on top of the material.

NOTICE

Dropping the mower straight down (pancaking) on heavy vegetation can cause severe damage to the disc and spindle.

CONTINUED ON NEXT PAGE

OPERATING TECHNIQUES

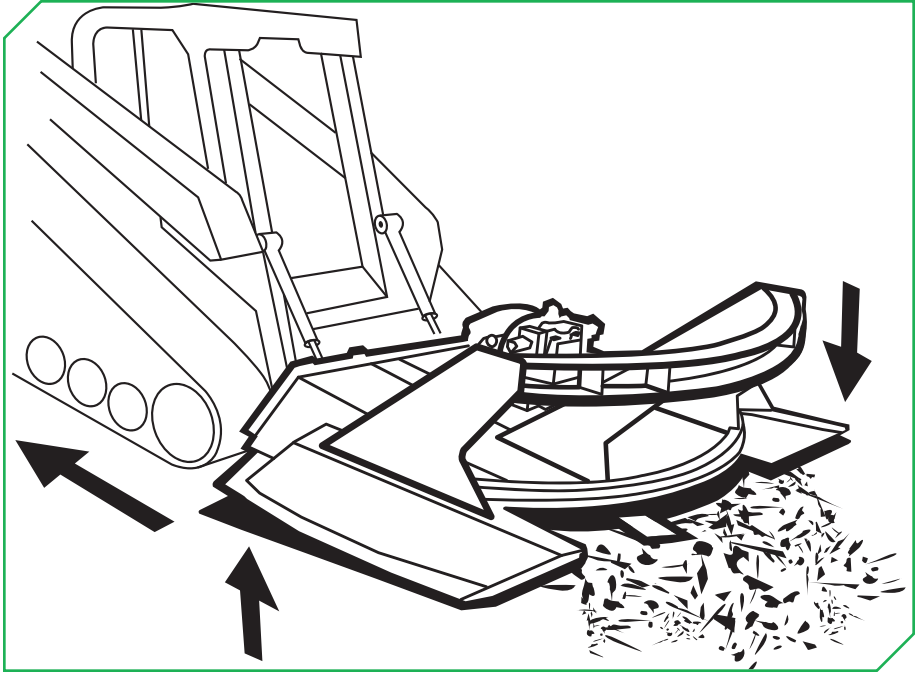

CLEANING & RE-PROCESSING

Use to clean up branches and large debris. Re-processing the debris will provide a groomed finish.

- Raise lift arms about 6" (152mm) and drop front of head toward the ground for the leading edge to skim the ground.
- Back over the remaining debris for a more finished look.

CONTINUED ON NEXT PAGE

OPERATING TECHNIQUES

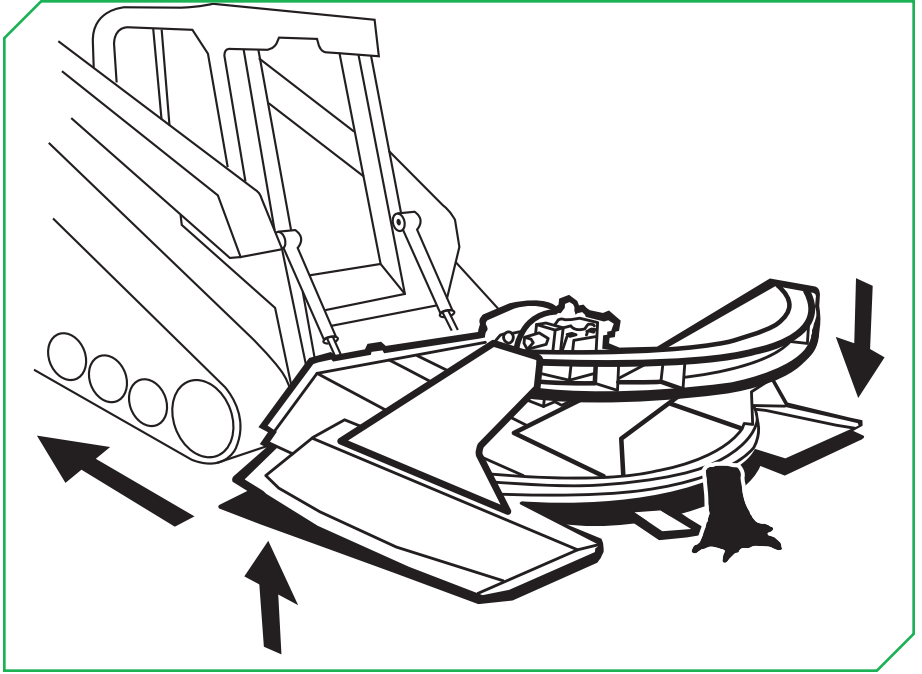

STUMP CUT

Use to cut stumps at, or below ground level.

- Keeping the deck level, cut the stump low to the ground.
- Wait to rebuild speed before proceeding with a stump cut.
- Lift up the deck and point the nose down to the ground to allow the blades to be closer to the ground.
- Drive over the stump again, cutting at or below ground level.

For more tips, visit us online at www.DiamondMowers.com

MAINTENANCE INTERVALS

Regular maintenance will make certain your unit stays productive and retains a long, operating life. The following chart represents the minimum intervals recommended for inspection and maintenance.

PROCEDURE	10 HOURS	50 HOURS	500 HOURS/ ANNUALLY	AS NEEDED
Blades	Inspect			
Castle Nuts/Roll Pins	Inspect			
Chain Curtain		Inspect		
Disc	Inspect			
Hydraulic Hoses & Fittings	Inspect			
Motor Bolts	Inspect			
Push Bars				Inspect
QD Couplers				Inspect
Safety Enclosure				Clean
Skid Shoes		Inspect		
Spindle	Inspect		Change Oil	
Spindle Bolts	Inspect			

When replacing parts, use Genuine Diamond Parts. Guaranteed to ship within 72-hours of your order being placed, or the parts and shipping are free.

Call: 888-960-0361 or 605.977.3300 | **Email:** parts@diamondmowers.com

Order online: www.diamondmowers.com

CONTINUED ON NEXT PAGE

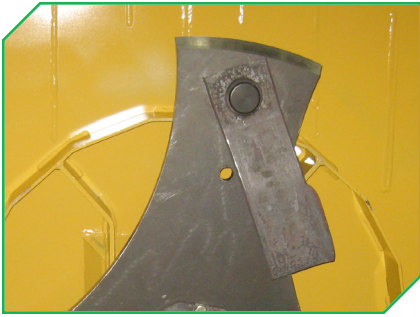

BLADES

- Blades should be inspected every 10 hours, depending on usage.
- Inspect the blades for any cracks or damage.
- Blades that show 50% wear from original width should be replaced. Blades should be replaced as a set of three to maintain balance.

To replace a blade:

- Remove the roll pin, castle nut, and blade bolt.
- Replace the blade.
- Using new hardware, torque castle nuts to 400ft-lbs (543Nm). **DO NOT** use Loctite.
- Refer to **CASTLE NUT & ROLL PIN** for installation specifications.

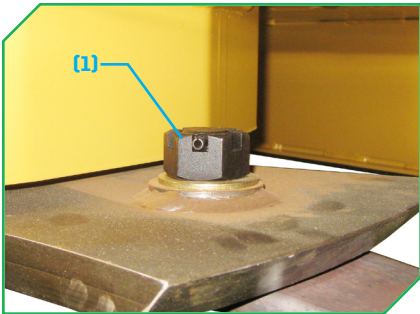

CASTLE NUT & ROLL PIN

- Castle nuts and roll pins (1) should be inspected every 10 hours, or daily.
- Access to castle nuts can be reached from the front of the deck, or through the deck's access cover (2).

If a roll pin is missing:

- Torque castle nut to 400ft-lbs (543Nm).
- Replace the roll pin.
- If the roll pin cannot be inserted after the castle nut has been torqued, continue to torque the castle nut until the roll pin will fit.



CONTINUED ON NEXT PAGE



CHAIN GUARD

The chain guard is *OPTIONAL*, and may not be present on your model.

- Chain guard hardware should be inspected every 50 hours, or weekly.
- The chain guard, its steel cables, and its cable clamps should be inspected every 50 hours, or weekly.
- Replace as necessary.

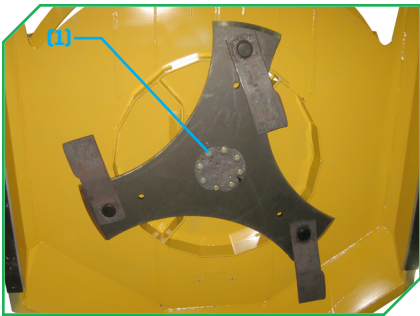

DISC

- Disc should be inspected every 10 hours, or daily.
- Raise and secure the deck to inspect the disc for any cracks or other damage. If damage is found, disc should be replaced.

If disc bolts **u** are loose:

- Remove the bolts.
- Apply Loctite 262 (red) to the threads.
- Replace the bolts and torque to 212ft-lbs (287Nm).

CONTINUED ON NEXT PAGE



HYDRAULIC HOSES & FITTINGS

- Hydraulic hoses and fittings should be inspected every 10 hours, or daily.

What to look for:

- Hydraulic fitting clamps and threaded connections for any hydraulic fluid.
 - If any leaks are observed, stop immediately to prevent damage to your machine.
- Hoses for any abrasions or cuts. Replace damaged or worn hoses.
- Attach hose wrap around critical points where hoses are likely pinched or rubbed.

CAUTION

DO NOT check for hydraulic leaks with your hands or any part of your body. Use a heavy piece of paper or cardboard to check areas that are not readily visible. Pressurized hydraulic fluid can penetrate the skin and lead to serious health risks or death.

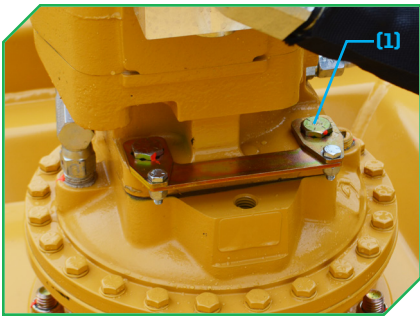

MOTOR BOLTS

- Motor bolts⁽¹⁾ should be inspected every 10 hours, or daily.
- Torque hardware to 110ft-lbs (149Nm).
- Verify that locking tabs are in place.
- Assemble locking tabs to the U-shaped tab over the cab bolts with their hardware. Torque hardware to 75in-lbs (8.5Nm).

CONTINUED ON NEXT PAGE



PUSH BAR

- Check for cracks.
- Repair as necessary.



SHATTER RESISTANT ENCLOSURE

- **REQUIRED!** Debris can be thrown unexpectedly in any direction. Do not attempt to use this unit without proper protection.
- Clean only with mild soap and water using a sponge or soft cloth.
- Replace as necessary.



SKID SHOES

- Skid shoes should be inspected every 50 hours, or weekly.
- Replace as necessary.

CONTINUED ON NEXT PAGE

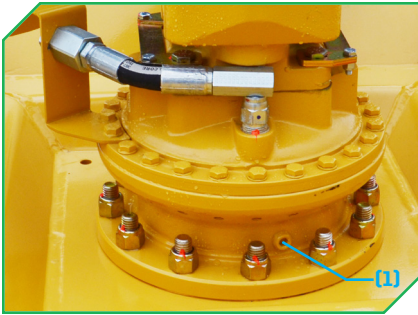

SPINDLE

- Inspect topside of the cutting disc for oil.
 - If oil is present, the spindle's lower bearing seal may be damaged and will require replacement.
- The disc should rotate smoothly.
 - If excessive play is found, the spindle bearings are likely worn and will require replacement.
- Drain and replace oil annually or every 500 hours with 32oz of 75w90 synthetic gear oil.
 - Remove motor shield, drain plug ⁽¹⁾ facing forwards, and fill plug ⁽²⁾ on opposite side facing operator.
 - Tilt head down/forward over oil catch pan until all oil stops draining, then replace drain plug.
 - Fill spindle with oil, then replace fill plug.
- Keep the pressure relief area ⁽³⁾ free of debris every 10 hours or daily.
 - **NOTE:** Oil leaking while operating indicates a motor seal failure.

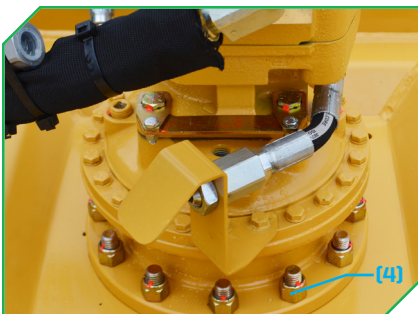
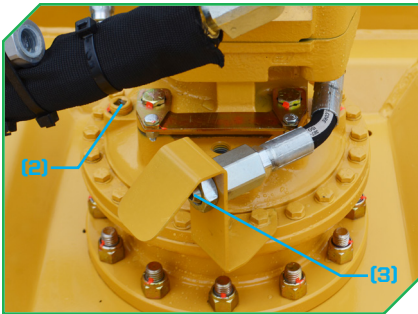

SPINDLE BOLTS

- Spindle bolts and nuts ⁽⁴⁾ must be inspected every 10 hours, or daily.
- If bolts come loose, remove, apply Loctite 262 (red) to threads and reinstall.
- Torque hardware to 212ft-lbs (287Nm).

NOTICE

Failure to inspect and replace hardware at recommended intervals will cause damage to the Machine and Skid-Steer / Compact Track Loader.

TROUBLESHOOTING

PROBLEMS	POTENTIAL CAUSE	SOLUTION
Disc Will Not Spin	No hydraulic flow from skid steer / compact track loader	Verify hydraulic flow from power unit.
	Failed splined insert	Replace splined insert. <ul style="list-style-type: none"> ● Remove motor from spindle. ● Remove the spindle cover. ● Thread a 3/4-16 by 3" bolt into the insert base, forcing it out of the spindle. ● Replace spindle insert. ● Replace spindle cover. Torque spindle cover hardware to 45ft-lbs (61Nm). ● Replace motor and torque hardware to 110ft-lbs (149Nm). ● Replace lock tab hardware and torque to 75in-lbs (8.5Nm).
	Reversed flow from skid loader	After connecting the hoses to the machine, start machine at low idle and verify that the disc is spinning clockwise.
	Hydraulic motor shaft failure	Will require replacement. Contact Diamond Parts at 888.960.0361 or 605.977.3300.
	Material jammed	Dislodge material from disc by first disengaging the implement and backing up. This will typically clear the cutting head. If the cutting head does not clear, shut down the implement and rest the head on the ground. Clear the head manually. <ul style="list-style-type: none"> ● DO NOT use extremities to dislodge debris from blades or disc.

CONTINUED ON NEXT PAGE

PROBLEMS	POTENTIAL CAUSE	SOLUTION
Excessive Vibration	Disc to spindle hardware is loose	Tighten hardware <ul style="list-style-type: none"> ● Torque hardware to 212ft-lbs (287Nm).
	Vegetation build up on disc	Clean disc to remove debris by first disengaging the implement and backing up. This will typically clear the cutting head. If the cutting head does not clear, shut down the implement and rest the head on the ground. After the disc has come to a complete stop, clear the head manually. <ul style="list-style-type: none"> ● DO NOT use extremities to dislodge debris from teeth or disc.
	Missing or broken blade	Replace blade. <ul style="list-style-type: none"> ● Remove the blade bolt. ● DO NOT use Loctite. ● Use a torque wrench set to torque to 400ft-lbs (543Nm). <ul style="list-style-type: none"> ○ If the roll pin cannot be inserted after the castle nut has been torqued, continue to torque the castle nut until the roll pin will fit.
	Excessive play in spindle	The disc should rotate smoothly <ul style="list-style-type: none"> ● If excessive play is found, the spindle bearings are likely worn and will require replacement. Contact Diamond Parts at 888.960.0361 or 605.977.3300.

PROBLEMS	POTENTIAL CAUSE	SOLUTION
Disc Slows Quickly	skid-steer / compact track loader is operating on standard flow vs. high flow	Ensure skid steer / compact track loader is on high flow.
	Need to replace blades	Replace blade. <ul style="list-style-type: none"> ● Remove the blade bolt. ● DO NOT use Loctite. ● Use a torque wrench set to torque to 400ft-lbs (543Nm). <ul style="list-style-type: none"> ○ If the roll pin cannot be inserted after the castle nut has been torqued, continue to torque the castle nut until the roll pin will fit.

For any questions, contact our Warranty / Service team at
888.960.0364 or 605.977.3300



ROTARY MOWER
PARTS BOOK

60"(1524mm) DECK

25-1327

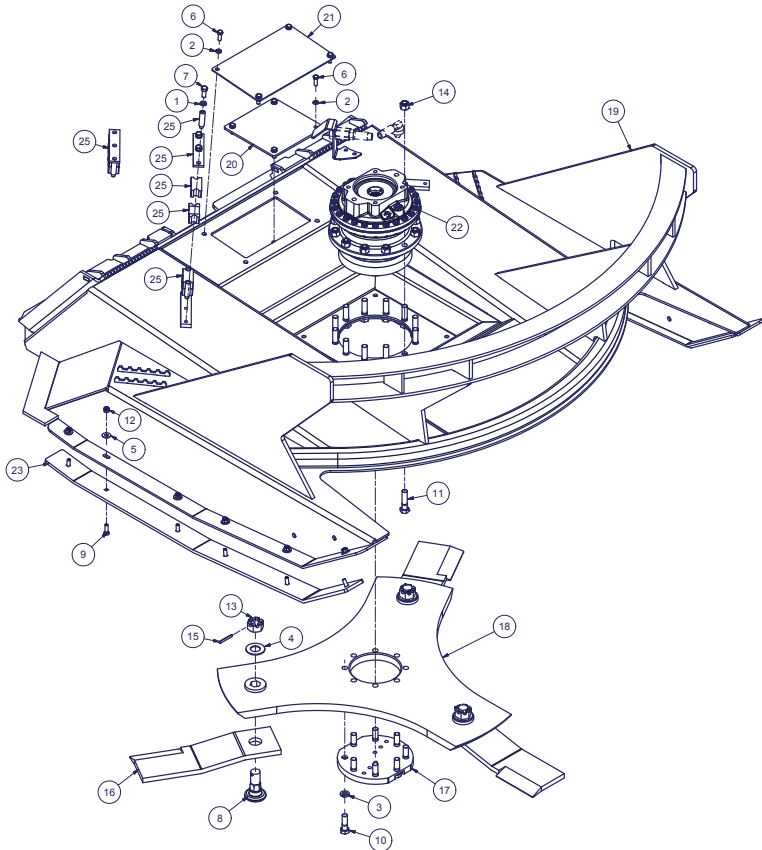

REF#	PARTS DESCRIPTION	REQ	PART#	TORQUE (ft-lbs)	TORQUE (Nm)
1	7/16 LOCK WASHER GR 5	3	11-0003		
2	3/8 LOCK WASHER GR 5	8	11-0005		
3	5/8 LOCK WASHER GR 8	8	11-0043		
4	1-1/8 SAE FLAT WASHER GR 8	3	11-0057		
5	3/8 FLAT WASHER GR 8	12	11-0092		
6	3/8 X 1 NC HEX CAP	8	11-0532	30.9	41.9
7	7/16 X 1 NC HEX CAP	3	11-0584	49.4	67.0
8	D3 BLADE BOLT	3	11-0759		
9	3/8 X 1-1/4 NC PLOW BOLT	12	11-0804	30.9	41.9
10	5/8 X 2 NC HEX CAP, GR 8	8	11-0970	211.9	287.3
11	5/8 X 2-1/2 NC HEX CAP, GR 8	12	11-0971	211.9	287.3
12	3/8 NC NYLOCK NUT	12	11-1024		
13	1-1/8-12 NF SLOTTED HEX NUT GR 8	3	11-1050		
14	5/8 NC NYLOCK NUT, GR. 8	12	11-1073		
15	1/4 ROLL PIN x 2	3	11-2005		
16	BRUSH BLADE - 5/8	3	22-0006		
17	BOLT PROTECTOR, 60 FBS, AUBURN	1	24-0224		
18	60 INCH TRI-HEX DISH D3	1	24-0298		
19	D3 60" DLR	1	25-0230		
20	60 SKID FBC ACCESS PORT COVER	1	31-0455		
21	UPPER DECK COVER, FBS060, D3	1	31-0537		
22	D3 SPINDLE, DIRECT DRIVE, REMOVEABLE SPLINED INSERT	1	35-0093		
23	SKID SHOE, 60" SKID STEER - PUSH BAR	2	42-0033		
24	BLADE KIT (Includes 11-0057, 11-0759, 11-1050, 11-2005, & 22-0006)	1	44-0228		
25	1" HOSE CLAMP KIT	1	44-0259		

72"(1829mm) DECK

25-1323

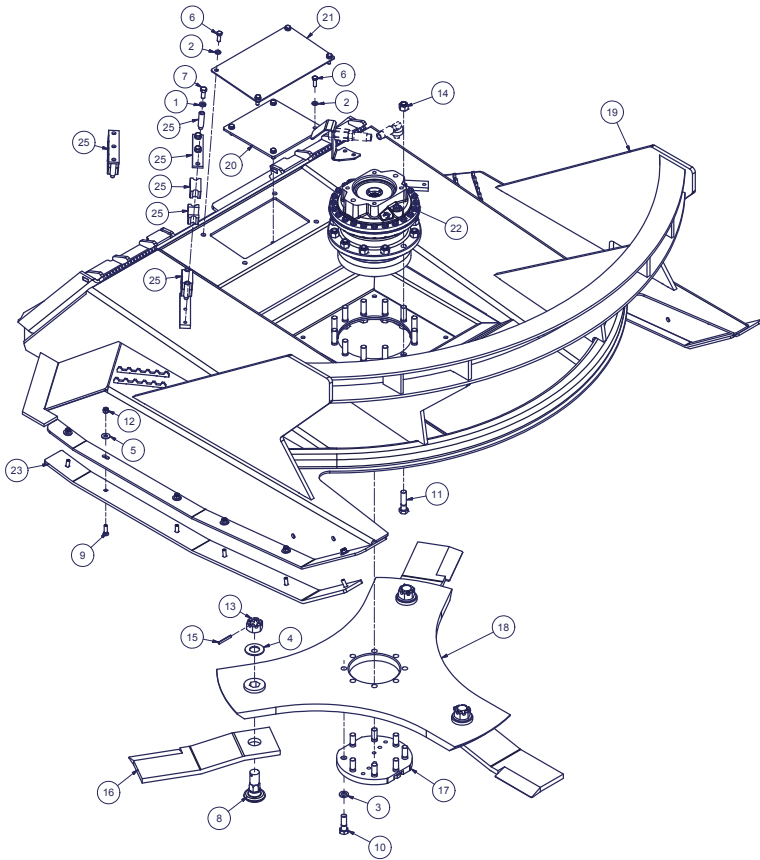

REF#	PARTS DESCRIPTION	REQ	PART#	TORQUE (ft-lbs)	TORQUE (Nm)
1	7/16 LOCK WASHER GR 5	3	11-0003		
2	3/8 LOCK WASHER GR 5	8	11-0005		
3	5/8 LOCK WASHER GR 8	8	11-0043		
4	1-1/8 SAE FLAT WASHER GR 8	3	11-0057		
5	3/8 FLAT WASHER GR 8	12	11-0092		
6	3/8 X 1 NC HEX CAP	8	11-0532	30.9	41.9
7	7/16 X 1 NC HEX CAP	3	11-0584	49.4	67.0
8	D3 BLADE BOLT	3	11-0759		
9	3/8 X 1-1/4 NC PLOW BOLT	12	11-0604	30.9	41.9
10	5/8 X 2 NC HEX CAP, GR 8	8	11-0970	211.9	287.3
11	5/8 X 2-1/2 NC HEX CAP, GR 8	12	11-0971	211.9	287.3
12	3/8 NC NYLOCK NUT	12	11-1024		
13	1-1/8-12 NF SLOTTED HEX NUT GR 8	3	11-1050		
14	5/8 NC NYLOCK NUT, GR. 8	12	11-1073		
15	1/4 ROLL PIN x 2	3	11-2005		
16	BRUSH BLADE - 5/8	3	22-0006		
17	BOLT PROTECTOR, 60 FBS, AUBURN	1	24-0224		
18	72 INCH TRI-HEX DISH D3	1	24-0285		
19	D3 72" DLR	1	25-0220		
20	60 SKID FBC ACCESS PORT COVER	1	31-0455		
21	UPPER DECK COVER, FBS060, D3	1	31-0537		
22	D3 SPINDLE, DIRECT DRIVE, REMOVEABLE SPLINED INSERT	1	35-0093		
23	SKID SHOE, 72" SKID STEER - PUSH BAR	2	42-0032		
24	BLADE KIT (Includes 11-0057, 11-0759, 11-1050, 11-2005, & 22-0006)	1	44-0228		
25	1" HOSE CLAMP KIT	1	44-0259		

84"(2134mm) DECK

25-1442

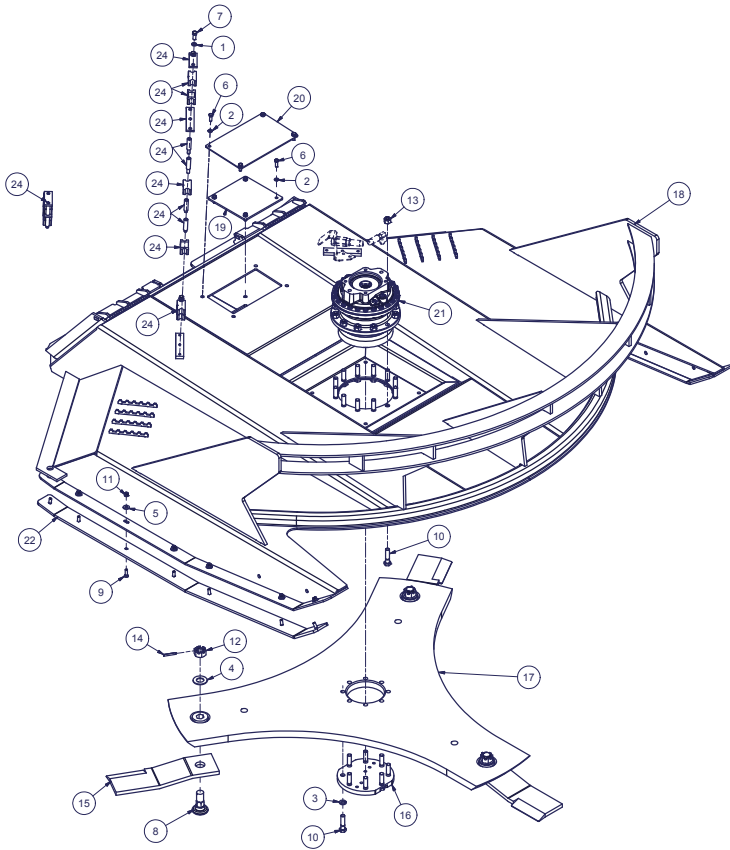

REF#	PARTS DESCRIPTION	REQ	PART#	TORQUE (ft-lbs)	TORQUE (Nm)
1	7/16 LOCK WASHER GR 5	3	11-0003		
2	3/8 LOCK WASHER GR 5	8	11-0005		
3	5/8 LOCK WASHER GR 8	8	11-0043		
4	1-1/8 SAE FLAT WASHER GR 8	3	11-0057		
5	3/8 FLAT WASHER GR 8	14	11-0092		
6	3/8 X 1 NC HEX CAP	8	11-0532	30.9	41.9
7	7/16 X 1 NC HEX CAP	3	11-0584	49.4	67.0
8	D3 BLADE BOLT	3	11-0759		
9	3/8 X 1-1/4 NC PLOW BOLT	14	11-0804	30.9	41.9
10	5/8 X 2-1/2 NC HEX CAP, GR 8	20	11-0971	211.9	287.3
11	3/8 NC NYLOCK NUT	14	11-1024		
12	1-1/8-12 NF SLOTTED HEX NUT GR 8	3	11-1050		
13	5/8 NC NYLOCK NUT, GR. 8	12	11-1073		
14	1/4 ROLL PIN x 2	3	11-2005		
15	BRUSH BLADE- 5/8	3	22-0006		
16	BOLT PROTECTOR, 60 FBS, AUBURN	1	24-0224		
17	24-0301 REF/ASSEMBLYWELD PRINT	1	24-0301		
18	84 D3 DLR	1	25-0231		
19	60 SKID FBC ACCESS PORT COVER	1	31-0455		
20	UPPER DECK COVER, FBS060, D3	1	31-0537		
21	D3 SPINDLE, DIRECT DRIVE, REMOVEABLE SPLINED INSERT	1	35-0093		
22	84" SKID LOADER, SHOE	2	42-0043		
23	BLADE KIT (Includes 11-0057, 11-0759, 11-1050, 11-2005, & 22-0006)	1	44-0228		
24	1" HOSE CLAMP KIT WITH TOP CLAMP, NO BASE	1	44-0351		

CHAIN GUARD (OPTIONAL)

60"(1524mm), 72"(1829mm), and 84"(2134mm) DECKS

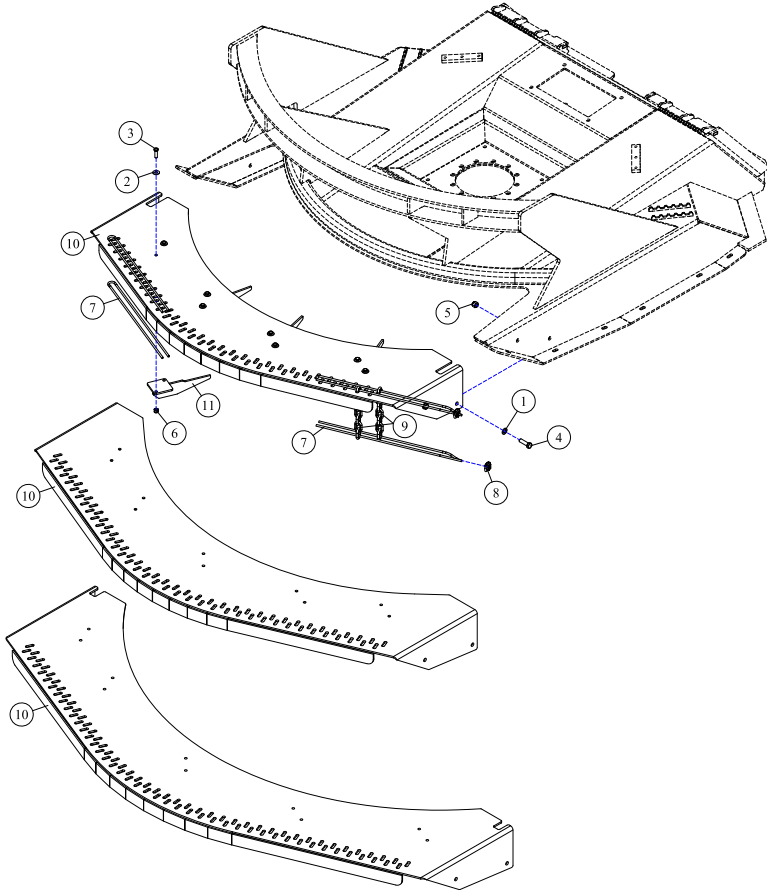

REF#	PARTS DESCRIPTION	REQ	PART #
1	1/2 SAE FLAT WASHER GR8	4	11-0042
2	3/8 SAE FLAT WASHER GR8		11-0090
	On 60" DLR	8	
	On 72" DLR	10	
	On 84" DLR	10	
3	3/8 X 1-1/4 NC HEX CAPSCREW		11-0533
	On 60" DLR	8	
	On 72" DLR	10	
	On 84" DLR	10	
4	1/2 X 1-3/4 NC HEX CAPSCREW	4	11-0535
5	1/2 NC NYLOCK NUT	4	11-1018
6	3/8 NC NYLOCK NUT		11-1024
	On 60" DLR	8	
	On 72" DLR	10	
	On 84" DLR	10	

REF#	PARTS DESCRIPTION	REQ	PART #
7	1/4 GALVANIZED CABLE (SOLD PER FOOT)		12-0032
	On 60" DLR	22	
	On 72" DLR	26	
	On 84" DLR	30	
8	1/4 WIRE ROPE CLAMP	2	12-0033
9	5/16 ZINC CHAIN - 7 LINKS GRADE 30		12-0036
	On 60" DLR	59	
	On 72" DLR	73	
	On 84" DLR	85	
10	CHAIN GUARD		
	D3 DLR CHAIN GUARD 60"	1	41-1636
	D3 DLR CHAIN GUARD 72"	1	41-1635
	D3 DLR CHAIN GUARD 84"	1	41-1637
11	BOLT ON CHAIN GUARD RIB		41-1653
	On 60" DLR	4	
	On 72" DLR	5	
	On 84" DLR	5	

DECAL IDENTIFICATION

60"(1524mm), 72"(1829mm), and 84"(2134mm) DECKS

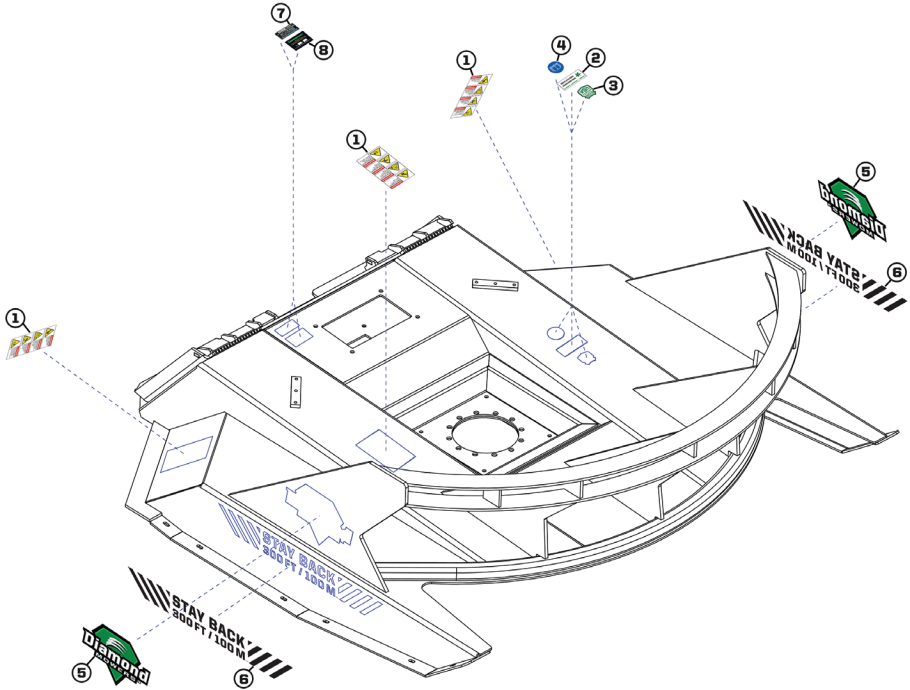

REF#	PARTS DESCRIPTION	REQ	PART #
1	"DANGER" DECAL GROUP A (vertical)	3	15-0056
2	"WARRANTY AND SERVICE"	1	15-1016
3	"MADE IN THE USA"	1	15-0055
4	"READ MANUAL"	1	15-0058
5	"DIAMOND MOWERS" LOGO (13 inch)	2	15-0053
6	"STAY BACK 300ft / 100m"	2	15-0059
7	SERIAL NUMBER LABEL	1	
8	FLOW RANGE LABEL	1	

PRESSURE RELIEF VALVE

60" (1524mm), 72" (1829mm), and 84" (2134mm) DECKS

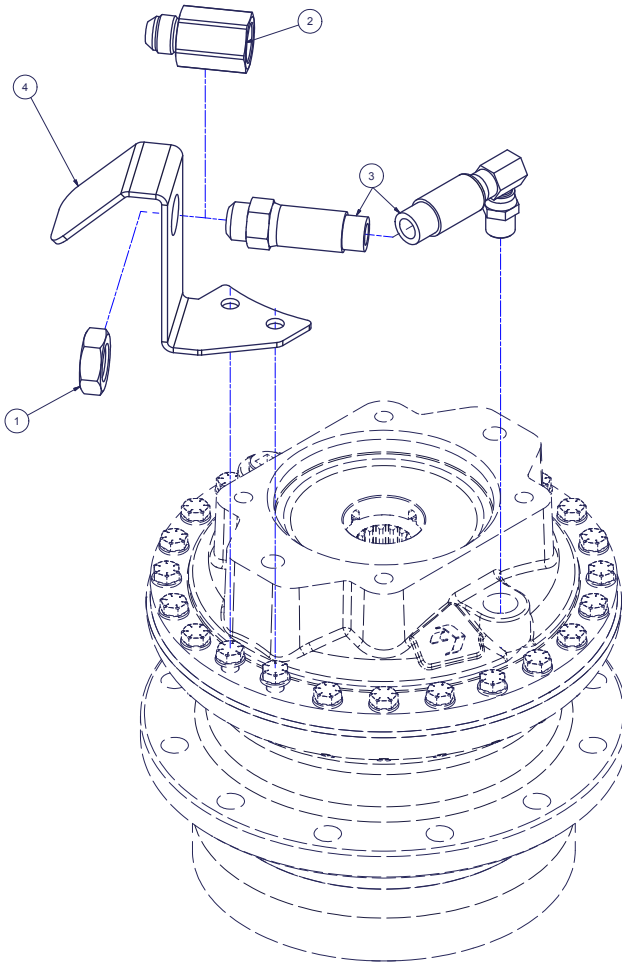



REF#	PARTS DESCRIPTION	REQ	PART#	TORQUE (ft-lbs)	TORQUE (Nm)
1	7/8 UNF JAM NUT	1	11-1159		
2	JEMTEC D3 SPINDLE RELIEF VALVE	1	21-1853		
3	HOSE 1/2 X 8 (5/8 JIC - 1/2 MP 90 DEG SWIVEL)	1	21-2419		
4	D3 RELIEF VALVE MOUNT	1	31-0688		

How to Determine Your Motor Part Number

60"(1524mm), 72"(1829mm), and 84"(2134mm) DECKS

NOTE: The following parts pages of drive assemblies have multiple motor options to identify which motor you have. Determine your machine GPM (LPM) hydraulic oil requirements, and follow the instructions below:

- Determine your machine hydraulic oil flow specifications in Gallons Per Minute (GPM).
- Locate the appropriate drive assemblies page for your mower size and equivalent GPM range on the following drive assembly parts pages.
- If multiple motor options are specified on the appropriate parts page, measure  the width of the gear set section of your motor in inches to determine which motor and part number on the following drive assembly parts pages is the correct replacement for your motor. Measure  the gear section shown in the illustration below.

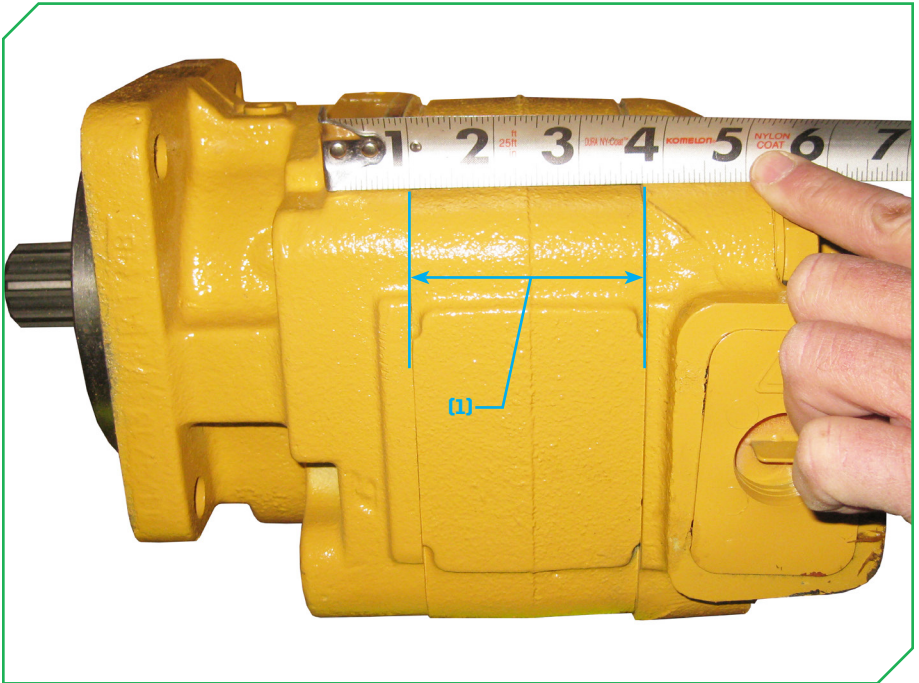

DRIVE ASSEMBLY: 16-28 GPM (61-106 LPM)
60"(1524mm) DECK

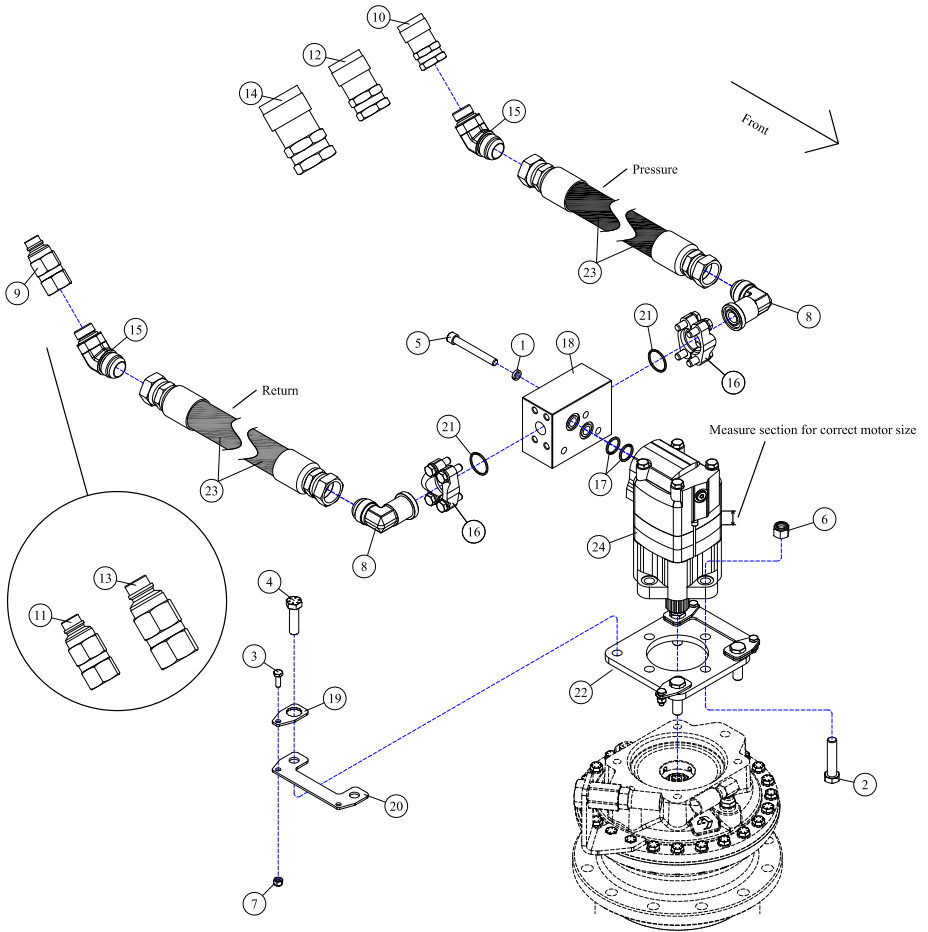

REF#	PARTS DESCRIPTION	REQ	PART #
1	3/8 HI-COLLAR LOCK WASHER	3	11-0054
2	1/2 X 2-1/4 NC HEX CAPSCREW	4	11-0531
3	1/4 X 3/4 NC HEX CAP	4	11-0588
4	1/2 X 1-1/2 NC HEX CAP GR.8	4	11-0972
5	3/8 X 2-1/2 NC SOCKET HEAD CAPSCREW	3	11-0701
6	1/2 NC NYLOCK NUT	4	11-1018
7	1/4 NC NYLOCK NUT	4	11-1022
8	#12FLG X IMJIC-90DEG ADAPTER	2	21-1302
9	1/2 MALE QUICK COUPLER, FLAT FACE	1	21-1559
10	1/2 FEMALE QUICK COUPLER, FLAT FACE	1	21-1560
11	5/8 MALE QUICK COUPLER, FLAT FACE	1	21-1574
12	5/8 FEMALE QUICK COUPLER, FLAT FACE	1	21-1575
13	3/4 MALE QUICK COUPLER, FLAT FACE	1	21-1576
14	3/4 FEMALE QUICK COUPLER, FLAT FACE	1	21-1577
15	ADAPTER, IMJIC-45DEGX 3/4MORB	2	21-1654

REF#	PARTS DESCRIPTION	REQ	PART #
16	#12 FLANGE KIT	2	21-2186
17	O-RING (SMALL) (included with #30-1206)	2	30-1205
18	PRESSURE AND RETURN BLOCK (included with motors)	1	30-1206
19	MOTOR BOLT LOCK TAB	4	31-0503
20	MOTOR BOLT LOCK BASE	2	31-0504
21	O-RING (LARGE) (included with #21-2186)	2	33-0062
22	MOTOR ADAPTER	1	35-0105
23	HOSE 1" (1EJIC X 1EJIC)		
	"STANDARD", PRESSURE & RETURN 103"	2	21-4345
	"OPTIONAL UPGRADE" 4000 psi, PRESSURE 103"	1	21-4346
	"OPTIONAL UPGRADE" 4000 psi, RETURN 90"	1	21-4365
24	MOTOR (includes #30-1206)		
	2000 SERIES, 11/16" SECT, 16-23 GAL/MIN	1	30-0528
	2000 SERIES, 7/8" SECT, 24-28 GAL/MIN	1	30-0529

DRIVE ASSEMBLY: 29-46 GPM (110-141 LPM)
60" (1524mm) DECK

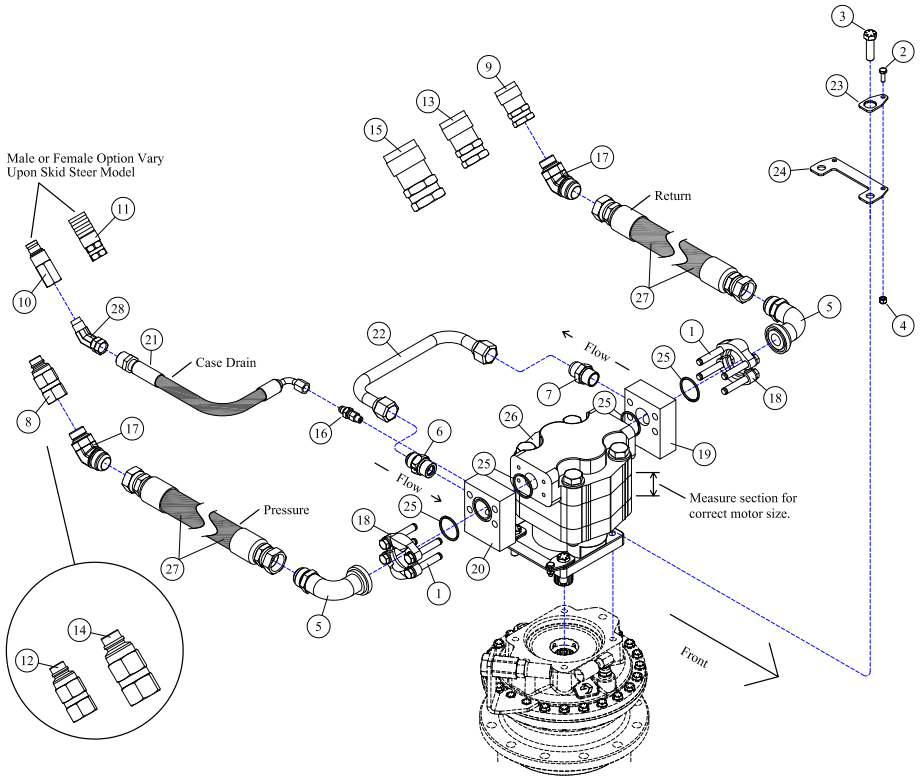

REF#	PARTS DESCRIPTION	REQ	PART #
1	7/16 X 3 NC HEX CAPSCREW (included with #19 & 20)	8	11-0587
2	1/4 X 3/4 NC HEX CAP	4	11-0588
3	1/2 X 1-1/2 NC HEX CAP GR 8	4	11-0972
4	1/4 NC NYLOCK NUT	4	11-1022
5	#20FLG X IMJIC-90DEG ADAPTER	2	21-1267
6	CHECK VALVE	1	21-1474
7	3/4 MORB X 3/4 MJIC ADAPTER	1	21-1475
8	1/2 MALE QUICK COUPLER, FLAT FACE	1	21-1559
9	1/2 FEMALE QUICK COUPLER, FLAT FACE	1	21-1560
10	3/8 MALE QUICK COUPLER, FLAT FACE	1	21-1561
11	3/8 FEMALE QUICK COUPLER, FLAT FACE	1	21-1562
12	5/8 MALE QUICK COUPLER, FLAT FACE	1	21-1574
13	5/8 FEMALE QUICK COUPLER, FLAT FACE	1	21-1575
14	3/4 MALE QUICK COUPLER, FLAT FACE	1	21-1576
15	3/4 FEMALE QUICK COUPLER, FLAT FACE	1	21-1577
16	ADAPTER, 1-4MOR X 3/8MIC	1	21-1597
17	ADAPTER, IMJIC-45DEG 3-4MORB	2	21-1654

REF#	PARTS DESCRIPTION	REQ	PART #
18	#20 FLANGE KIT (included with #19 & 20)	2	21-2105
19	CROSS OVER MANIFOLD KIT (includes #1, 18 & 25)	1	21-2180
20	TEE MANIFOLD KIT (includes #1, 18 & 25)	1	21-2181
21	HOSE 3/8 X 106 (3/8FJIC 90DEG X 1/2MP)	1	21-4290
22	RUN-AROUND TUBE	1	28-0051
23	MOTOR BOLT LOCK TAB	4	31-0503
24	MOTOR BOLT LOCK BASE	2	31-0504
25	O-RING (included with #18, 19 & 20)	4	33-0013
26	MOTOR		
	M365, 1-3/4" GEAR SET, 2-1/4" SECT, 29-35 GAL/MIN	1	30-0520
	M365, 2-1/4" GEAR SET, 2-3/4" SECT, 36-41 GAL/MIN	1	30-0524
	M365, 2-1/2" GEAR SET, 3" SECT, 42-46 GAL/MIN	1	30-0518
27	HOSE 1" (EJIC X EJIC)		
	"STANDARD", PRESSURE & RETURN 103"	2	21-4345
	"OPTIONAL UPGRADE" 4000 psi, PRESSURE 103"	1	21-4346
	"OPTIONAL UPGRADE" 4000 psi, RETURN 90"	1	21-4365
28	1/2MP X 1/2FP ADAPTER 45 DEG	1	21-1290

DRIVE ASSEMBLY: 29-41 GPM (110-155 LPM)
 72"(1829mm) DECK

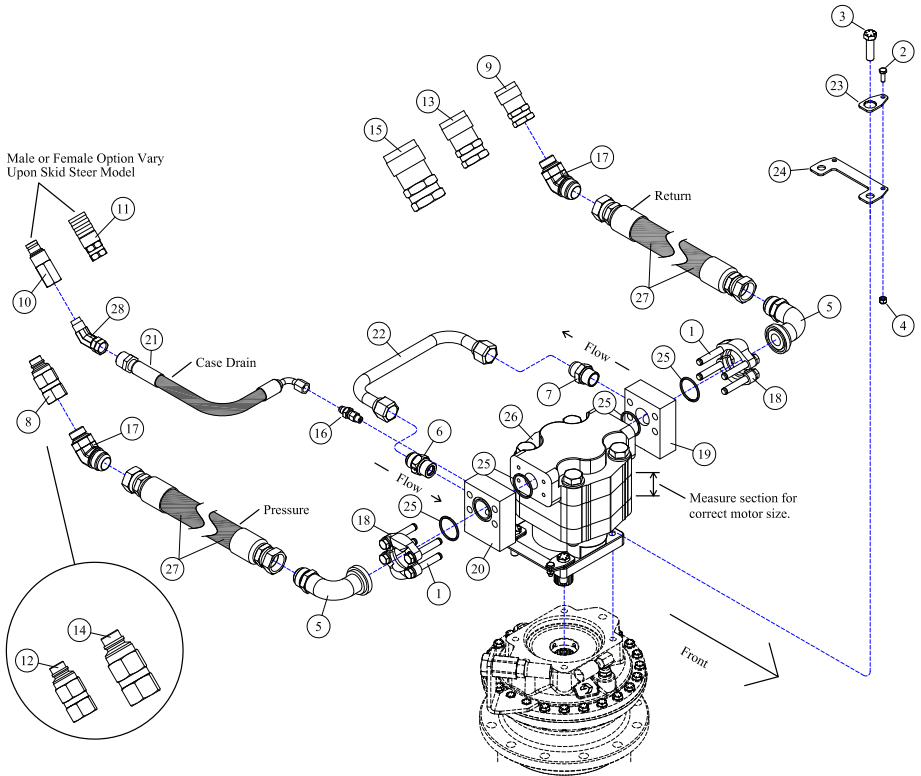

REF#	PARTS DESCRIPTION	REQ	PART #
1	7/16 X 3 NC HEX CAPSCREW (included with #19 & 20)	8	11-0587
2	1/4 X 3/4 NC HEX CAP	4	11-0588
3	1/2 X 1-1/2 NC HEX CAP GR 8	4	11-0972
4	1/4 NC NYLOCK NUT	4	11-1022
5	#20FLGX IMJIC-90DEG ADAPTER	2	21-1267
6	CHECK VALVE	1	21-1474
7	3/4 MORB X 3/4 MJIC ADAPTER	1	21-1475
8	1/2 MALE QUICK COUPLER, FLAT FACE	1	21-1559
9	1/2 FEMALE QUICK COUPLER, FLAT FACE	1	21-1560
10	3/8 MALE QUICK COUPLER, FLAT FACE	1	21-1561
11	3/8 FEMALE QUICK COUPLER, FLAT FACE	1	21-1562
12	5/8 MALE QUICK COUPLER, FLAT FACE	1	21-1574
13	5/8 FEMALE QUICK COUPLER, FLAT FACE	1	21-1575
14	3/4 MALE QUICK COUPLER, FLAT FACE	1	21-1576
15	3/4 FEMALE QUICK COUPLER, FLAT FACE	1	21-1577
16	ADAPTER, 1-4MOR X 3/8MIC	1	21-1597
17	ADAPTER, IMJIC-45DEGX 3-4MORB	2	21-1654

REF#	PARTS DESCRIPTION	REQ	PART #
18	#20 FLANGE KIT (included with #19 & 20)	2	21-2105
19	CROSS OVER MANIFOLD KIT (includes #1, 18 & 25)	1	21-2180
20	TEE MANIFOLD KIT (includes #1, 18 & 25)	1	21-2181
21	HOSE 3/8 X 106 (3/8FJIC 90DEG X 1/2MP)	1	21-4290
22	RUN-AROUND TUBE	1	28-0051
23	MOTOR BOLT LOCK TAB	4	31-0503
24	MOTOR BOLT LOCK BASE	2	31-0504
25	O-RING (included with #18, 19 & 20)	4	33-0013
26	MOTOR		
	M365, 2-1/4" GEAR SET, 2-3/4" SECT, 29-34 GAL/MIN	1	30-0524
	M365, 2-1/2" GEAR SET, 3" SECT, 35-41 GAL/MIN	1	30-0518
27	HOSE 1 X 103 (1EJIC X 1EJIC)		
	"STANDARD"	2	21-4345
	"OPTIONAL UPGRADE" 4000 psi	2	21-4346
28	1/2MP X 1/2FP ADAPTER 45 DEG	1	21-1290

DRIVE ASSEMBLY: 17-28 GPM (65-106 LPM)
72"(1829mm) DECK

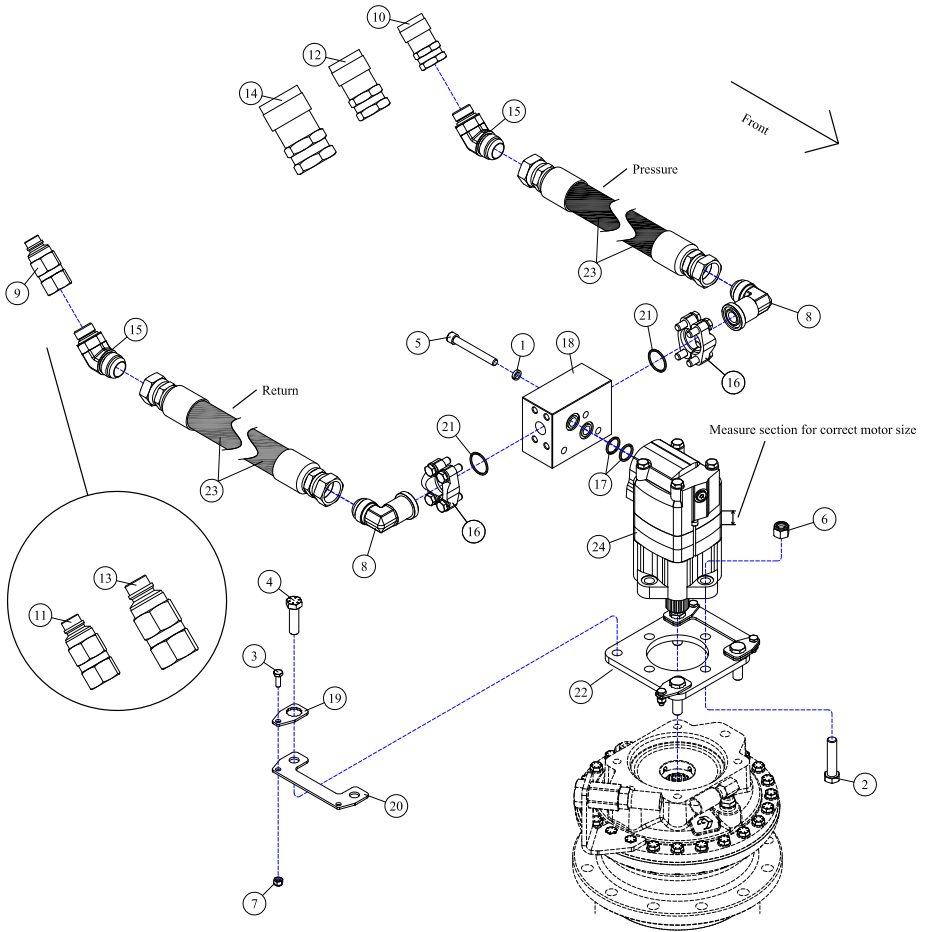

REF#	PARTS DESCRIPTION	REQ	PART #
1	3/8 HI-COLLAR LOCK WASHER	3	11-0054
2	1/2 X 2-1/4 NC HEX CAPSCREW	4	11-0531
3	1/4 X 3/4 NC HEX CAP	4	11-0588
4	1/2 X 1-1/2 NC HEX CAP GR 8	4	11-0972
5	3/8 X 2-1/2 NC SOCKET HEAD CAPSCREW	3	11-0701
6	1/2 NC NYLOCK NUT	4	11-1018
7	1/4 NC NYLOCK NUT	4	11-1022
8	#12FLGX IMJIC-90DEG ADAPTER	2	21-1302
9	1/2 MALE QUICK COUPLER, FLAT FACE	1	21-1559
10	1/2 FEMALE QUICK COUPLER, FLAT FACE	1	21-1560
11	5/8 MALE QUICK COUPLER, FLAT FACE	1	21-1574
12	5/8 FEMALE QUICK COUPLER, FLAT FACE	1	21-1575
13	3/4 MALE QUICK COUPLER, FLAT FACE	1	21-1576
14	3/4 FEMALE QUICK COUPLER, FLAT FACE	1	21-1577
15	ADAPTER, IMJIC-45DEGX 3/4MORB	2	21-1654

REF#	PARTS DESCRIPTION	REQ	PART #
16	#12 FLANGE KIT	2	21-2186
17	O-RING (SMALL) (included with #30-1206)	2	30-1205
18	PRESSURE AND RETURN BLOCK (included with motors)	1	30-1206
19	MOTOR BOLT LOCK TAB	4	31-0503
20	MOTOR BOLT LOCK BASE	2	31-0504
21	O-RING (LARGE) (included with #21-2186)	2	33-0062
22	MOTOR ADAPTER	1	35-0105
23	HOSE 1 X 103 (EJICX 1EJC) "STANDARD" "OPTIONAL UPGRADE" 4000 psi	2	21-4345
24	MOTOR (includes #30-1206) 2000 SERIES, 11/16" SECT, 17-20 GAL/MIN 2000 SERIES, 7/8" SECT, 21-28 GAL/MIN	1	30-0528
		1	30-0529

DRIVE ASSEMBLY: 32-41 GPM (122-155 LPM)
84"(2134mm) DECK

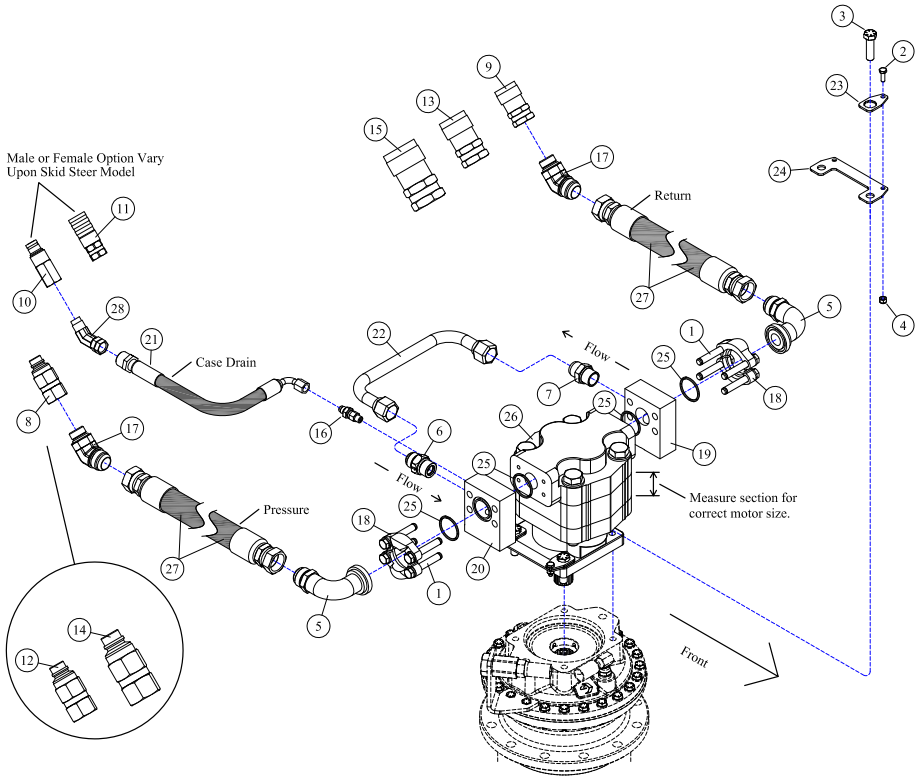

REF#	PARTS DESCRIPTION	REQ	PART #
1	7/16 X 3 NC HEX CAPSCREW (included with #19 & 20)	8	11-0587
2	1/4 X 3/4 NC HEX CAP	4	11-0588
3	1/2 X 1-1/2 NC HEX CAP GR 8	4	11-0972
4	1/4 NC NYLOCK NUT	4	11-1022
5	#20FLGX 1MJIC-90DEG ADAPTER	2	21-1267
6	CHECK VALVE	1	21-1474
7	3/4 MORBX 3/4 MJIC ADAPTER	1	21-1475
8	1/2 MALE QUICK COUPLER, FLAT FACE	1	21-1559
9	1/2 FEMALE QUICK COUPLER, FLAT FACE	1	21-1560
10	3/8 MALE QUICK COUPLER, FLAT FACE	1	21-1561
11	3/8 FEMALE QUICK COUPLER, FLAT FACE	1	21-1562
12	5/8 MALE QUICK COUPLER, FLAT FACE	1	21-1574
13	5/8 FEMALE QUICK COUPLER, FLAT FACE	1	21-1575
14	3/4 MALE QUICK COUPLER, FLAT FACE	1	21-1576
15	3/4 FEMALE QUICK COUPLER, FLAT FACE	1	21-1577
16	ADAPTER, 1/4MOR X 3/8MJIC	1	21-1597

REF#	PARTS DESCRIPTION	REQ	PART #
17	ADAPTER, 1MJIC-45DEGX 3/4MORB	2	21-1654
18	#20 FLANGE KIT (included with #19 & 20)	2	21-2105
19	CROSS OVER MANIFOLD KIT (includes #1, 18 & 25)	1	21-2180
20	TEE MANIFOLD KIT (includes #1, 18 & 25)	1	21-2181
21	HOSE 3/8 X 106 (3/8FJIC 90DEGX 1/2MP)	1	21-4290
22	RUN-AROUND TUBE	1	28-0051
23	MOTOR BOLT LOCK TAB	4	31-0503
24	MOTOR BOLT LOCK BASE	2	31-0504
25	O-RING (included with #18, 19 & 20)	4	33-0013
26	MOTOR M365, 2-1/2" GEAR SET, 3" SECT, 32-41 GAL/MIN	1	30-0518
27	HOSE 1 X 103 (1EJC X 1EJC) "STANDARD"	2	21-4345
	"OPTIONAL UPGRADE" 4000 psi	2	21-4346
28	1/2MP X 1/2FP ADAPTER-45 DEG	1	21-1290

DIRECT DRIVE SPINDLE
35-0093

REF#	PARTS DESCRIPTION	REQ	PART #
1	BEARING-CONE (TOP)	1	10-0094
2	BEARING-CUP (TOP)	1	10-0095
3	BEARING-CONE (BOTTOM)	1	10-0096
4	BEARING-CUP (BOTTOM)	1	10-0097
5	BOLT-HEX HEAD	24	11-1611
6	WASHER-FLAT	24	11-1612
7	RING-RETAINING	1	11-1613
8	NUT-LOCK	1	11-1614
9	WASHER-LOCK	1	11-1615
10	SCREW-SKT HD CAP	6	11-1616
11	PIPE PLUG (TO COVER) (MAGNETIC)	1	21-1609
12	PIPE PLUG (TO COVER) (NON-MAGNETIC)	1	21-1610
13	PIPE PLUG (TO HUB) (MAGNETIC)	2	21-1611
14	W ASHER-THRUST (TOP)	1	35-0096
15	COUPLING	1	35-0097
16	PLATE-KEEPER	1	35-0098
17	W ASHER-THRUST (BOTTOM)	1	35-0099
**18	HUB	1	35-0100
19	SEAL-OIL	1	35-0101
*20	GUARD	1	35-0102
**21	SHAFT-OUTPUT	1	35-0103
22	COVER		
	C BASE (STANDARD)	1	35-0094
	D BASE (OPTIONAL)	1	35-0095

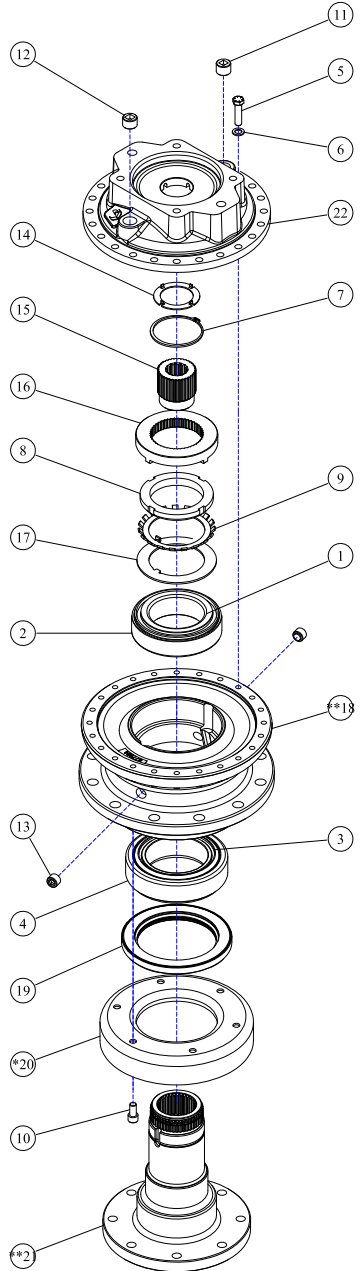

NOTE: WHEN ORDERING ANY ITEMS MARKED * ABOVE, ALSO ORDER SERVICE KIT 33-0078

NOTE: WHEN ORDERING ANY ITEMS MARKED ** ABOVE, ALSO ORDER SERVICE KIT 33-0079

SERVICE KITS

PART #	DESCRIPTION	INCLUDED ITEMS
33-0078	SEAL KIT	9, 19
33-0079	BEARING & SEAL KIT	1, 2, 3, 4, 9, 19
33-0080	COUPLER KIT	14, 15

KITS ALSO INCLUDE A TUBE OF SEALANT PART NO. 35-0104

30-0518 MOTOR ASSEMBLY

60"(1524mm), 72"(1829mm), and 84"(2134mm) DECKS

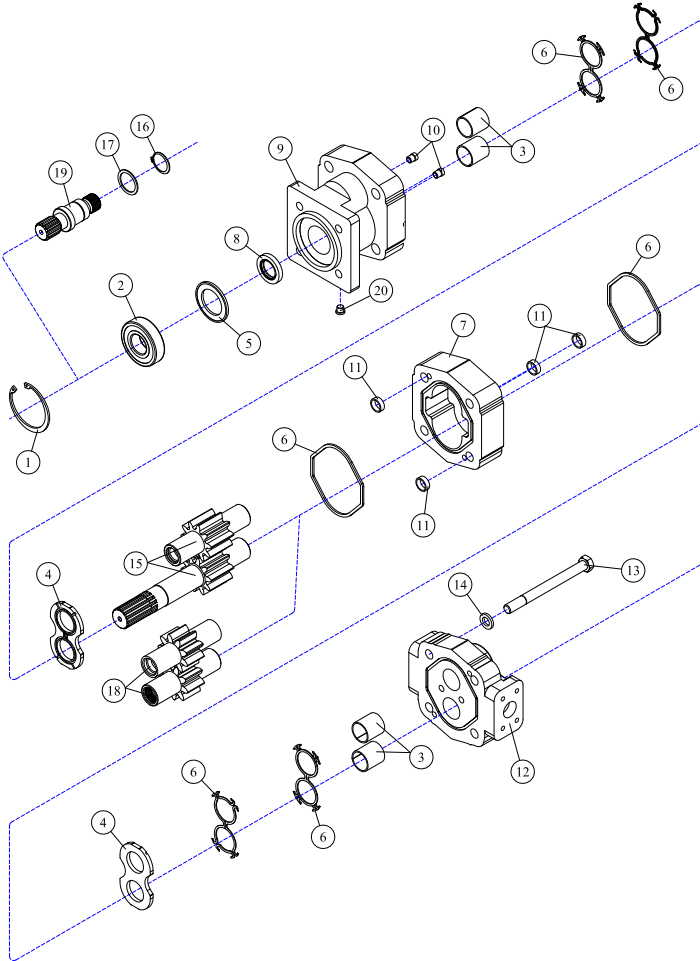

REF#	PARTS DESCRIPTION	REQ	PART #
1	SNAP RING	1	30-1009
2	OUTBOARD BEARING	1	30-1010
3	BUSHING	4	30-1011
4	THRUST PLATE	2	30-1012
5	SEAL RETAINER	1	30-1017
6	M365 SEAL KIT	Avail	30-1021
7	2-1/2" M365 GEAR HOUSING	1	30-1137
8	SHAFT SEAL 150 PSI (included in M365 seal kit) 500 PSI	1	30-1210 30-1156
9	SHAFT END COVER	1	30-1086
10	CHECK ASSEMBLY	2	30-1087
11	ALIGNMENT BUSHING	4	30-1090

REF#	PARTS DESCRIPTION	REQ	PART #
12	PORT END COVER	1	30-1091
13	STUD	4	30-1334
14	WASHER	4	30-1093
	GEAR SET OPTION A:		
15	2-1/2" GEAR SET	1	30-1170
	GEAR SET OPTION B:		
16	RETAININGRING	1	30-1019
17	WASHER	1	30-1020
18	2-1/2" GEAR SET	1	30-1136
19	CONTINENTAL SHAFT, SPLINED	1	30-1144
20	PLUG	1	30-1096
*	SEAL APPLICATOR TOOL (not shown)	Avail	30-1048

30-0520 MOTOR ASSEMBLY
60"(1524mm) DECKS

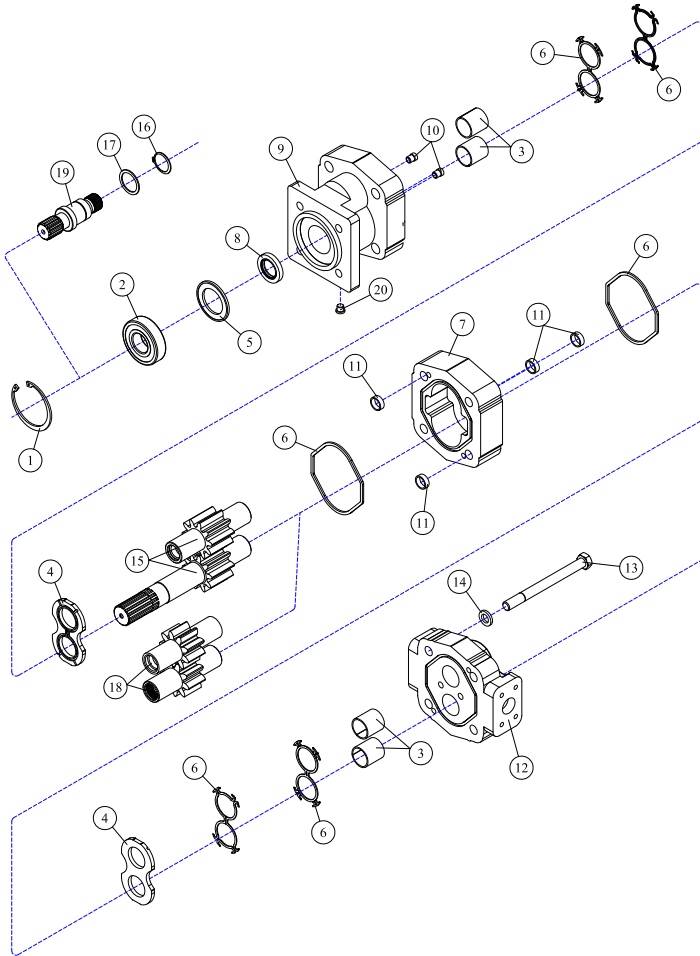

REF#	PARTS DESCRIPTION	REQ	PART #
1	SNAP RING	1	30-1009
2	OUTBOARD BEARING	1	30-1010
3	BUSHING	4	30-1011
4	THRUST PLATE	2	30-1012
5	SEAL RETAINER	1	30-1017
6	M365 SEAL KIT	Avail	30-1021
7	GEAR HOUSING	1	30-1015
8	SHAFT SEAL		
	150 PSI (included in M365 seal kit)	1	30-1210
	500 PSI	1	30-1156
9	SHAFT END COVER	1	30-1086
10	CHECK ASSEMBLY	2	30-1087
11	ALIGNMENT BUSHING	4	30-1090

REF#	PARTS DESCRIPTION	REQ	PART #
12	PORT END COVER	1	30-1091
13	STUD	4	30-1092
14	WASHER	4	30-1093
GEAR SET OPTION A:			
15	1-3/4" GEAR SET	1	30-1166
GEAR SET OPTION B:			
16	RETAINING RING	1	30-1019
17	WASHER	1	30-1020
18	1-3/4" GEAR SET	1	30-1013
19	CONTINENTAL SHAFT, SPLINED	1	30-1144
20	PLUG	1	30-1096
*	SEAL APPLICATOR TOOL (not shown)	Avail	30-1048

30-0524 MOTOR ASSEMBLY
 60"(1524mm) and 72"(1829mm) DECKS

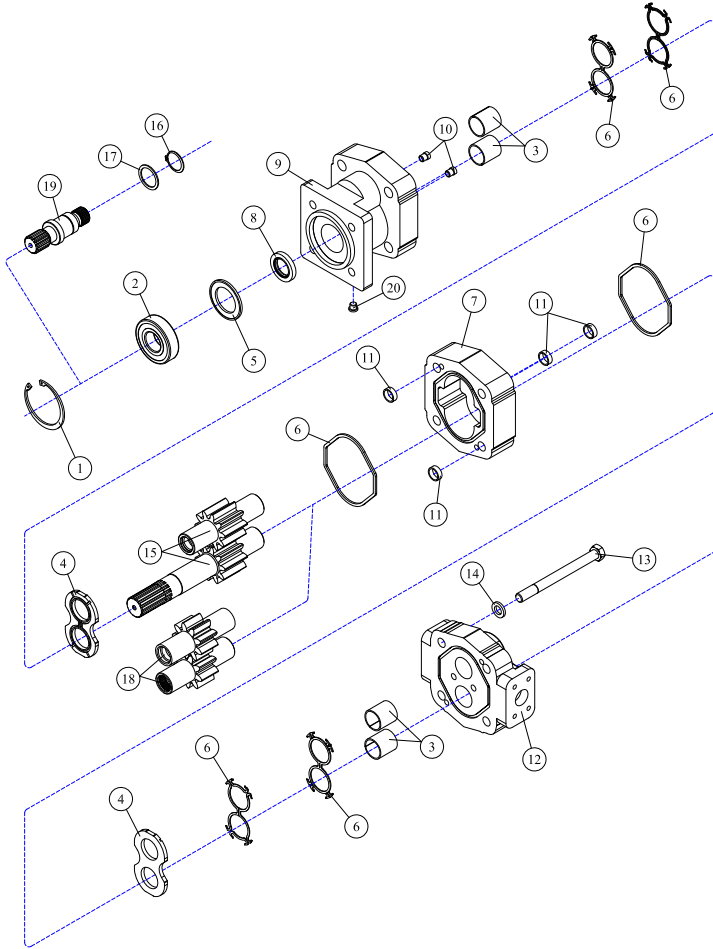

REF#	PARTS DESCRIPTION	REQ	PART #
1	SNAP RING	1	30-1009
2	OUTBOARD BEARING	1	30-1010
3	BUSHING	4	30-1011
4	THRUST PLATE	2	30-1012
5	SEAL RETAINER	1	30-1017
6	M365 SEAL KIT	Avail	30-1021
7	2-1/4" M365 GEAR HOUSING	1	30-1026
8	SHAFT SEAL		
	150 PSI (included in M365 seal kit)	1	30-1210
	500 PSI	1	30-1156
9	SHAFT END COVER	1	30-1086
10	CHECK ASSEMBLY	2	30-1087
11	ALIGNMENT BUSHING	4	30-1090

REF#	PARTS DESCRIPTION	REQ	PART #
12	PORT END COVER	1	30-1091
13	STUD	4	Call
14	WASHER	4	30-1093
GEAR SET OPTION A:			
15	2-1/4" GEAR SET	1	30-1165
GEAR SET OPTION B:			
16	RETAINING RING	1	30-1019
17	WASHER	1	30-1020
18	2-1/4" GEAR SET	1	30-1025
19	CONTINENTAL SHAFT, SPLINED	1	30-1144
20	PLUG	1	30-1096
*	SEAL APPLICATOR TOOL (not shown)	Avail	30-1048

30-0528 MOTOR ASSEMBLY
 60"(1524mm) and 72"(1829mm) DECKS

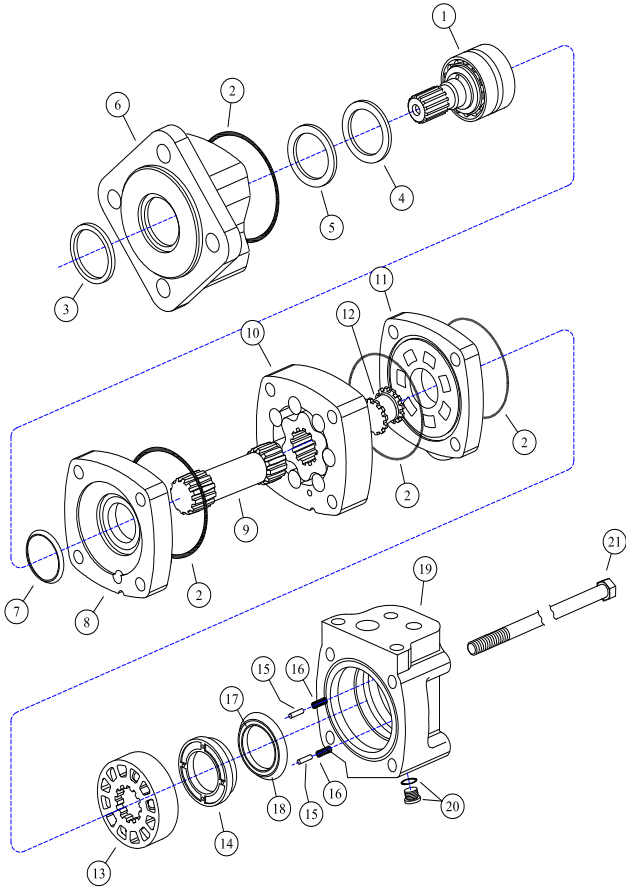

* Part included with item # 22 seal kit

REF#	PARTS DESCRIPTION	REQ	PART #
1	SHAFT & BEARING KIT (1-1/4" SPLINED 14T)	1	30-1311
2	SEAL	4	30-1312
3	SEAL, EXCLUSION	1	30-1313
4	SEAL, SHAFT	1	30-1314
5	RING, BACK-UP	1	30-1315
6	HOUSING, BEARING, DIAGONAL (FOUR BOLT)	1	30-1316
7	SEAL, SHAFT FACE	1	30-1317
8	PLATE, WEAR	1	30-1318
9	DRIVE, MAIN	1	30-1319
10	GEROLER	1	30-1320
11	PLATE, VALVE	1	30-1321
12	DRIVE, VALVE	1	30-1322

REF#	PARTS DESCRIPTION	REQ	PART #
13	VALVE	1	30-1323
14	BALANCE RING	1	30-1324
15	PIN, BALANCE RING	2	30-1325
16	SPRING, COMPRESSION	2	30-1326
17	SEAL, FACE, INNER	1	30-1327
18	SEAL, FACE, OUTER	1	30-1328
19	HOUSING, VALVE	1	30-1329
20	PLUG ASSEMBLY W/ O-RING	1	30-1309
	O-RING	1	30-1330
21	SCREW, CAP	4	30-1331
22	SEAL KIT	1	33-0064

30-0529 MOTOR ASSEMBLY 60"(1524mm) and 72"(1829mm) DECKS

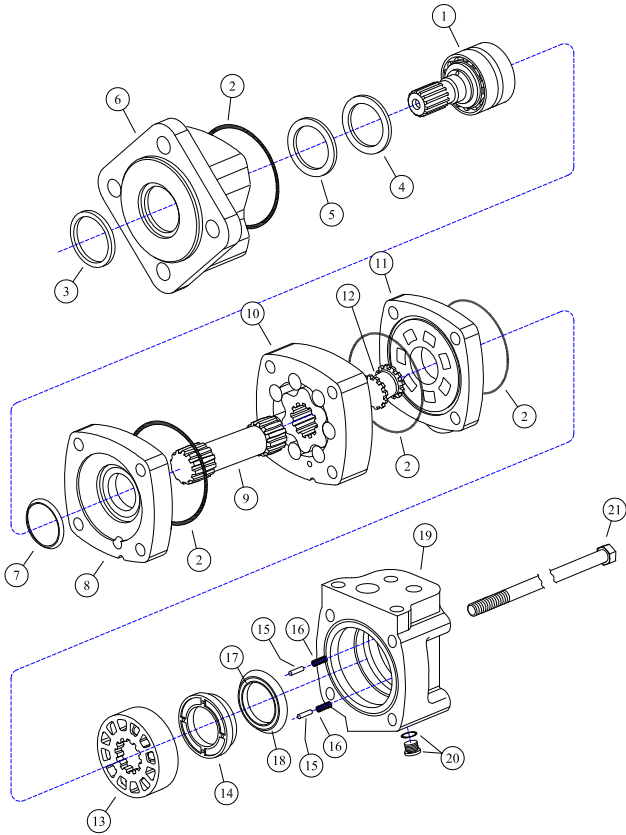

* Part included with item # 22 seal kit

REF#	PARTS DESCRIPTION	REQ	PART #
1	SHAFT & BEARINGKIT (1-1/4" SPLINED 14T)	1	30-1311
2	SEAL	4	30-1312
3	SEAL, EXCLUSION	1	30-1313
4	SEAL, SHAFT	1	30-1314
5	RING, BACK-UP	1	30-1315
6	HOUSING, BEARING, DIAGONAL (FOUR BOLT)	1	30-1316
7	SEAL, SHAFT FACE	1	30-1317
8	PLATE, WEAR	1	30-1318
9	DRIVE, MAIN	1	30-1319
10	GEROLER	1	30-1320
11	PLATE, VALVE	1	30-1321
12	DRIVE, VALVE	1	30-1322

REF#	PARTS DESCRIPTION	REQ	PART #
13	VALVE	1	30-1323
14	BALANCE RING	1	30-1324
15	PIN, BALANCE RING	2	30-1325
16	SPRING, COMPRESSION	2	30-1326
17	SEAL, FACE, INNER	1	30-1327
18	SEAL, FACE, OUTER	1	30-1328
19	HOUSING, VALVE	1	30-1329
20	PLUG ASSEMBLY W/ O-RING	1	30-1309
	O-RING	1	30-1330
21	SCREW, CAP	4	30-1331
22	SEAL KIT	1	33-0064

(This Page Intentionally Left Blank)

INDEX

- B**
 - Blades 7, 19
 - Bolts
 - Motor 21
 - Spindle 23
- C**
 - Castle Nut & Roll Pin 19
 - Chain Guard 20
- D**
 - Disc 7, 20
- H**
 - Hoses & Fittings 7, 9, 21
- I**
 - Intended Use 6
- M**
 - Machine Flow 8
 - Maintenance Intervals 18
- O**
 - Operation
 - Safety Tips 10
 - Stowed Position 11
 - Techniques
 - Cleaning & Re-Processing 16
 - Finished Mow 13
 - Grass & Brush Cut 12
 - No Pancaking 15
 - Stump Cut 17
 - Tree Cut 14
- P**
 - Parts Book 27
 - 60"(1524mm) Deck 28
 - 60"(1524mm) Drive Assembly
 - 16-28 GPM (61-106 LPM) 35
 - 29-46 GPM (110-141 LPM) 36
 - 72"(1829mm) Deck 29
 - 72"(1829mm) Drive Assembly
 - 17-28 GPM (65-106 LPM) 38
 - 29-41 GPM (110-155 LPM) 37
 - 84"(2134mm) Deck 30
 - 84"(2134mm) Drive Assembly
 - 32-40 GPM (122-152 LPM) 39
 - Chain Guard (Optional) 31
 - Decal Identification 32
 - Direct Drive Spindle 40
 - Motor Assembly 30-0518 41
 - Motor Assembly 30-0520 42
 - Motor Assembly 30-0524 43
 - Motor Assembly 30-0528 44
 - Motor Assembly 30-0529 45
 - Motor Part Number 34
 - Pressure Relief Valve 33
 - Pressure Relief 23
 - Product Information 2
 - Push Bar 7, 22
- Q**
 - QD Couplers 9
 - Quick Attach (Skid-Steer) 8
- S**
 - Shatter Resistant Enclosure 8, 22
 - Skid Shoes 22
 - Spindle 23
- T**
 - Troubleshooting 24
- W**
 - Welcome 3



**100% SATISFACTION
GUARANTEE**
★ GET IT, LOVE IT & LEAVE IT! ★

**72-HOUR PARTS
SHIPPING GUARANTEE**